

3rd Edition

POLSTORE



PROFESSIONAL STORAGE SOLUTIONS



“DO YOU FIT THE POLSTORE PROFILE?”

With an established reputation in the manufacturing and engineering sector for 58 years, we are more than a supplier of storage units. We are a solutions-based company with the main goal of giving you back time and making your life easier.

Primarily we design, manufacture, supply and install workshop and warehouse storage through our wide product range and reliable and trusted supply chain. We champion workshop storage solutions in heavy use environments – it creates efficiency, reduces waste, lowers costs, improves attitude, and motivates people within the workplace.

Our passion for sustainable design and manufacture filters through to all our product ranges. Buying into our product range attracts the type of client who has a passion for precise engineering design, who embraces detail, understands true quality and cares for that purchase decision.

As a team our mission is to supply a consistent high-end storage product ensuring the client experiences an exceptional level of service. For more complex needs, we work together with trusted sub-contractors throughout the UK and Europe, so that we can support you with full turnkey projects.

Our brochure shares first-hand accounts of how we have brought exceptional storage solutions to life for our clients. We're as passionate and committed about our solutions, as you are about your own workspace. Our experienced project sales team can offer advice from concept design through to installation, 100% confident that we can exceed expectations and will not walk away until we have.

We are a solutions-based company with the main goal of giving you back time and making your life easier.

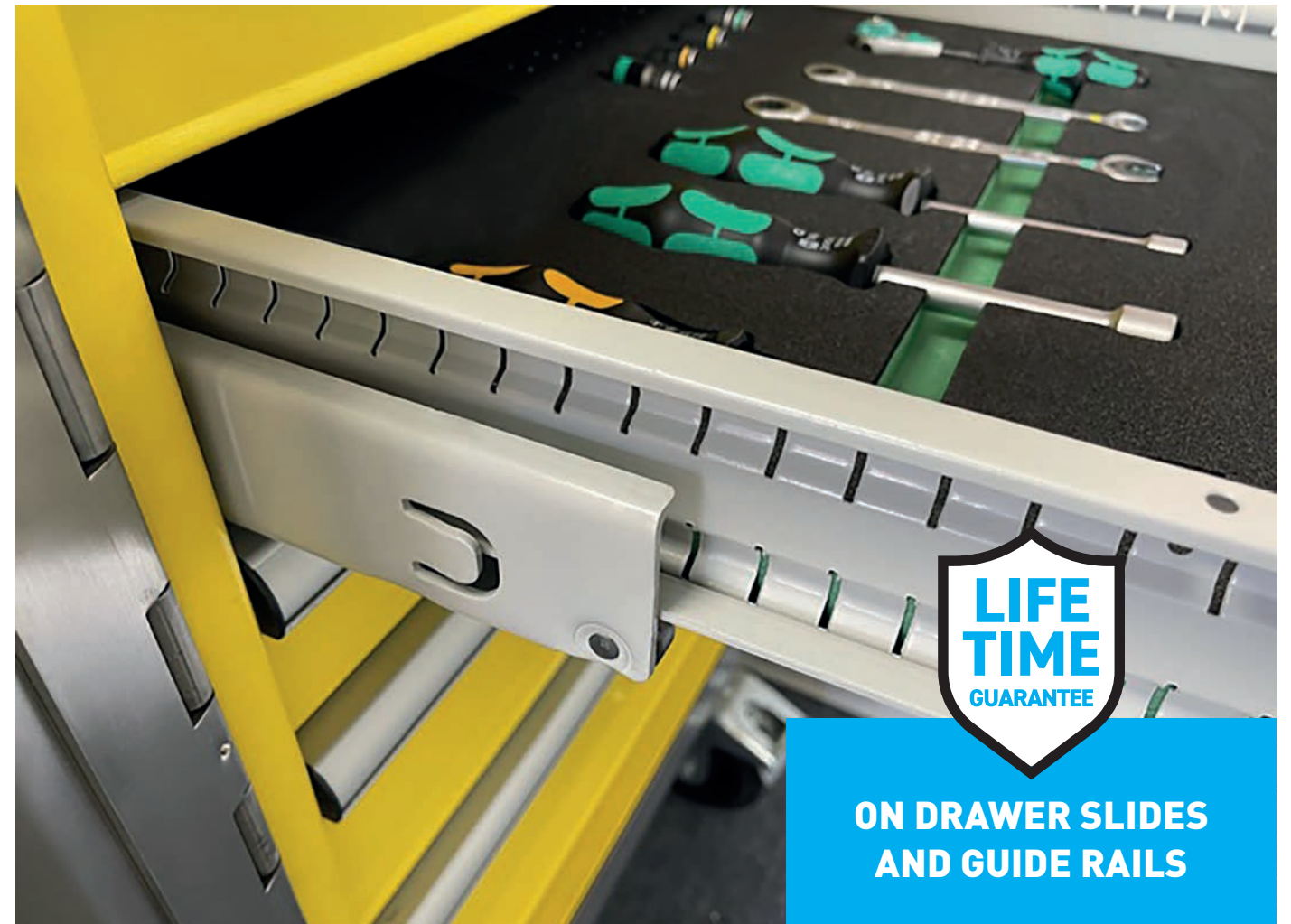

ON DRAWER SLIDES AND GUIDE RAILS

2	About Us	18-21	Plastic Unibox
3	Contents	22-29	Combo Drawer Cabinets
4-5	Thinking Outside The Box	30-47	Drawer Cabinets
6-7	Why We Do It Better	48-51	Combo Workbenches
8-9	WOW in Workshop Storage	52-61	Workbenches
10-11	Foams Tool & Asset Control	62	Anti-Fatigue Matting
12-13	Warehouse Storage & Handling Solutions	63	Roller Shutter Cabinets
14-15	Secure Storage Solution	64-67	Hooks for Perforated Back Panels
16	eLOQ	68-73	Computer Cabinets
17	Product Index	74-75	CNC Storage & Transport
		76-77	Storage Cupboards
		78-79	Trolleys Series 77



THINKING OUTSIDE THE BOX

*Adam Lucas,
Managing Director,
testing the weight load of a cabinet drawer!*



One of my earliest memories of the business was assembling guide rails into 9400 cabinets the wrong configuration and being ticked off by our Stores Manager for wasting his time – harsh but I can now appreciate his impatience. I was always in awe of all the manufacturing equipment there and how from old school rough sketches stunning storage systems were created.

As soon as I was able to work, I joined the business, which my parents started in 1963. I started in the welding and fabrication areas, and eventually progressed to running the warehouse. I was extremely fortunate to be mentored by experienced engineers, to learn my skills from the very best, in my opinion. Their focus, their precision, their finesse. It was a privilege to work alongside them and memories I will never forget.

This is what I'm determined to carry through the business in the decades to come. For new joiners to come in and absorb the skills and passion from those who've done the same with the generation before them. It's a bit like keeping the original engineers my parents recruited alive in the business, fifty years on and beyond.

Why is that important to me? Quite frankly, it's how the business has grown to be the success it is today, and I believe it's shaped the man I am today also. When I'm discussing a client's needs with them, I just instinctively know what it is that they need and what will give them a long term workspace storage solution. It's been



instilled in me, from the very beginning, the importance of really listening to my clients. Every solution is bespoke to each client, because the solution is as unique as they are. When they work with Polstore, they get our collective years of experience which means we ask the right questions in order to dissect their challenges, and identify the right solution quickly.

Our business wouldn't be here today if we didn't innovate and challenge the status quo though. Making small incremental improvements over time transforms the work we do and that for me is true

“Our business wouldn't be here today if we didn't innovate and challenge the status quo”

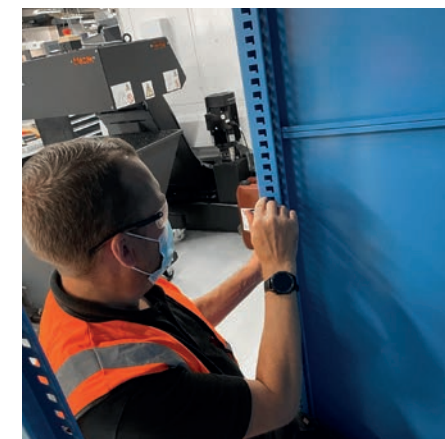

job satisfaction. And it's not just me leading this change; it's a culture created within Polstore. We all challenge each other to think differently and to consider alternatives and ultimately achieve a better solution.

I'm always looking to move the business forward and find innovative new product offerings to improve the service to our clients. A recent example of this development in action are the new plastazote routed foam shadow boards and foam inserts we now offer as part of our tool and asset control solutions. We introduced the customised foam inlays in 2020 because they are an extremely cost-effective way to protect any asset; tools, fixtures or artefacts. We use the latest CAD/CAM software and our Trend CNC 3-axis machine, to create plastazote in different colours and thicknesses and the end result can be seen as a work of art!

This year we've introduced our new ranges of warehouse storage and handling solutions as well as garage workshop storage solutions. We're also increasing our client base within motorsport and car restoration in addition to our core sectors of expertise in Education, Engineering, Heritage and Military

Whatever I'm working on, now and in the future, my first priority is building a great and happy team. If there's one business lesson I've learnt, it's that Polstore would not be what it is today without its people. I want people to want to work for Polstore because it's a great place to work, enjoyable, with good people and of course, exceptional products and great clients.

WHY WE DO IT BETTER?

Our drawer cabinets are tough and robust, even after 40 years of heavy use they are still in service.

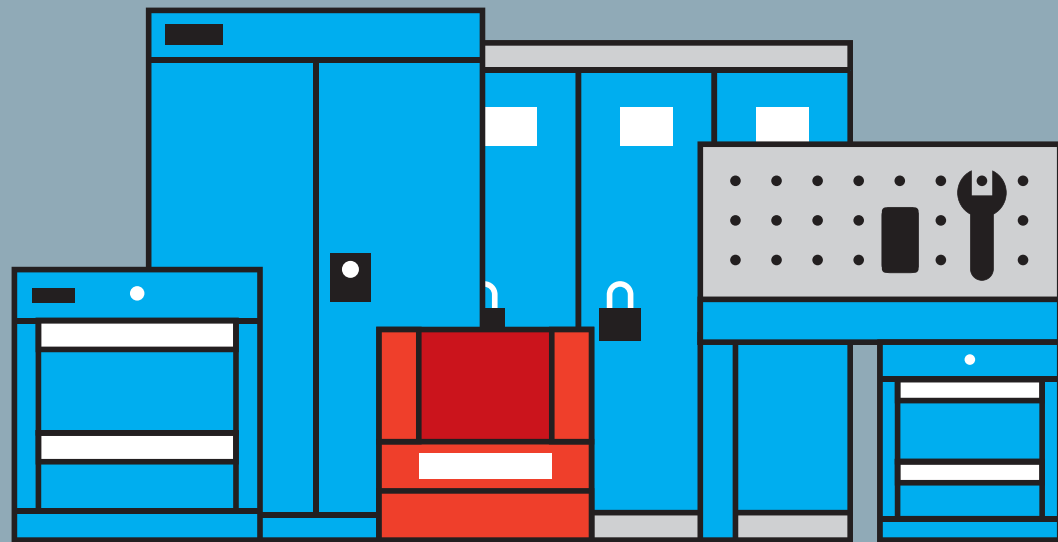

01 WELDED CONSTRUCTION Put us to the test, put some weight in it

No pop rivets or clip systems, which is why there is zero twist or distortion under load, ensuring smooth drawer movement, each and every time (4500kg SWL/cabinet). Use as a bench or machine stand freeing up valuable workshop space.

02 NON-CORROSIVE Built to last – two layer process

Our environmentally friendly painting process ensures a high resistant coating – all metalwork is initially dipped and painted inside and out to eliminate corrosion. A second coat is then applied colour choice dependant.

03 PAINT FINISH Key for durability and after all you want it to look good

All products are supplied in a smooth semi-gloss paint finish. If you want to customise – go ahead, we can do what you want!

04 POSITIVE LOCKING SYSTEM The one thing, you don't want to fail

A strong steel vertical locking bar rotates to create a positive locking system. The anti-tilt mechanism ensures you can only open one drawer at a time. Supplied with two keys (Master key available). **Upgrade to electronic locking.**

05 CABINET SIZE It makes for quite a decision

There is a multitude of sized Polstore cabinets. The system is purposely designed to be modular so you can create any specification, allowing the cabinets to be re-configured at any time.

06 DRAWER & SLIDE SYSTEM Super smooth action – more weight the better

Manufactured from steel the top of the drawer has a secondary fold to avoid sharp edges giving the drawer strength and stability. The handle is anodised and can be removed if damaged avoiding full drawer replacement. A neat labelling system is supplied comprising of a paper card insert and plastic cover strip. There are 2 types of drawers – NORMAL = 90% extension with a max load per drawer of 100kg. FULL = 100% extension with a max load of 200kg per drawer.

07 DRAWER DIVIDER KITS Get creative, don't overlook this

The side walls of the drawers have location slots every 17mm allowing for the installation of a large range of drawer divider kits. The drawer base is perforated to enable partitions to be mechanically fixed stopping migration of items stored.

08 ACCESSORIES FOR YOUR CABINET Personalise and upgrade – stand out from the crowd

Two-way pallet bases allow you to move the cabinet with a pallet truck or forklift, at a moment's notice. Base plinths for raising the cabinet from the floor, preventing damage, wear and flood risk. Hinged lockable doors creating a drawer / cupboard mix. 3 & 4 sided upstand and removable smooth rubber mat – stopping items rolling off and transforming the top of the cabinet into a work surface. Perforated panels and hook kits can be fixed to the back of the cabinet for hanging tools and other items. Worktops can be supplied in a number of materials and finishes, turning your cabinet into a robust and useful workbench.

Polstore drawer storage cabinets thrive on weight loads – the heavier the load stored, the smoother the movement. 100% of the drawer volume is used as the height of the drawer side and rear matches the drawer front. This prevents loose storage items falling out from the sides.



CREATING THE **‘WOW’** IN WORKSHOP STORAGE



There were three components to this workshop storage solution. Firstly, our premium CNC and machine tool storage shelving system with sliding lockable doors and pull-out drawers with a load capacity of 200kg – fitted with internal tool cradles and CNC tool holders essential for the heavy tooling. Reassuringly, our drawer cabinets are covered by our 5-year warranty and all our drawer slides and guide rails are covered by a lifetime warranty.

Secondly, we provided 2 types of industrial workbench systems - a 3-metre-long workbench and multi-station hexagonal bench. Each were made up with a combination of workshop drawer cabinets which were tailored to their needs with bench mounted roller shutter cabinets and tool shadow boards.

A popular product we see engineering clients invest in to organise the drawer internals, is our routed foam inserts. These are a cost-effective storage solution which instantly alerts a user if an item is missing through a very simple visual cue.

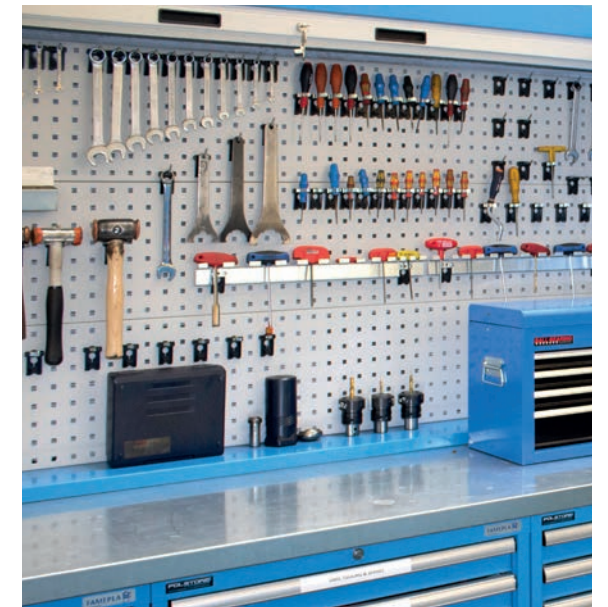

The third and final aspect of this client's storage solution were the pull-out vertical drawers for storing small parts and consumable tooling. Each drawer is fitted out with our plastic tilt bin system 'Unibox'. Here the tools are easy to see and access using transparent compartments of various sizes. The vertical pull out drawer system has a 500kg SWL rating per drawer perfect for industrial environments.

The Polstore team is as passionate and committed about storage solutions as our clients are about workspaces. We offer a full service from discussing your needs through to exceeding expectations at install and handover.

We're proud of the results we bring to our clients, knowing they will stand the test of time, heavy repetitive use and still create the 'wow' factor!



If it's a bespoke workshop fit out you are looking for – call us on 0800 008 6861 or email enquiries@polstore.co.uk, to see how we can help you.

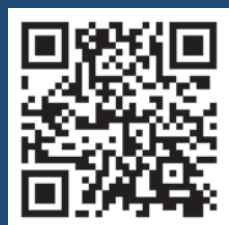

First impressions count. The brief to Polstore from this engineering customer was that the workshop storage put in place delivers the 'wow' factor!





**IT'S WHAT'S
ON THE INSIDE
THAT COUNTS.**



Having an organised and accessible workspace allows you to maintain focus on your daily tasks. Consider the time which could be saved from knowing exactly where your tools and equipment are, precisely when you need them. Productivity can be hindered by simply walking around the workshop, hunting down tools, whilst easily building up frustration amongst the team.

Foam inlays add that final piece of finesse to organisation within your workshop. They can be integrated within any of our storage solutions, including protective cases, container trays and tool cabinets. Extremely cost-effective, anything can be protected - tools, fixtures, artefacts.

Designed and manufactured in-house at Polstore, we use different grades of plastazote, a man-made polyethylene, which is chemically inert, flexible, oil proof, waterproof, non-toxic and odourless. Plastazote can also be used in different colours and thicknesses to deliver a unique storage solution for your assets. In fact, apply some bold colours and you can easily identify any missing items!

Our customised designs are created in just a few simple steps. Data capture, profiling, design, approval, then creation. We can remove the inconvenience of items being taken "off-site" and data capture can be completed at your premises, and even train your team to complete the data capture themselves, for objects of a sensitive nature.

This is where the experience of our team excels. We're as passionate and committed about storage solutions as you are, and the six-stage process which we follow ensures that the end result we deliver is exceptional. Take your workspace organisation to the next level with customised foam inlays.

**Please contact us on
0800 008 6861 or
enquiries@polstore.co.uk
for any requirements
you may have.**

Warehouses by nature are larger in size, but this doesn't mean there's space to waste. Housing large or multiple objects means the use of every square inch needs to be maximised. Our warehouse and handling solutions allows you to optimise the space for your needs today, and in the future, giving you a truly long-term dynamic storage solution.

The key to our cost-effective storage solutions is flexibility. With our extensive range of shelving and racking accessories and a series of solutions, an infinite number of designs can be achieved.

Industrial pallet racking and longspan shelving can be easily configured in a variety of ways to enable your business to increase capacity, productivity and efficiency and focus on the task in hand.

The addition of mobile shelving systems can speed up storage and retrieval times, as well save up to 80% in floor space with the same storage volume.

As your requirements change, simply reconfigure your storage system as and when required suiting a variety of applications.

With qualified and professional installers Polstore has the expertise and resources to deliver an exceptional warehouse storage solution just for you.

FLEXIBLE WAREHOUSE STORAGE & HANDLING SOLUTIONS

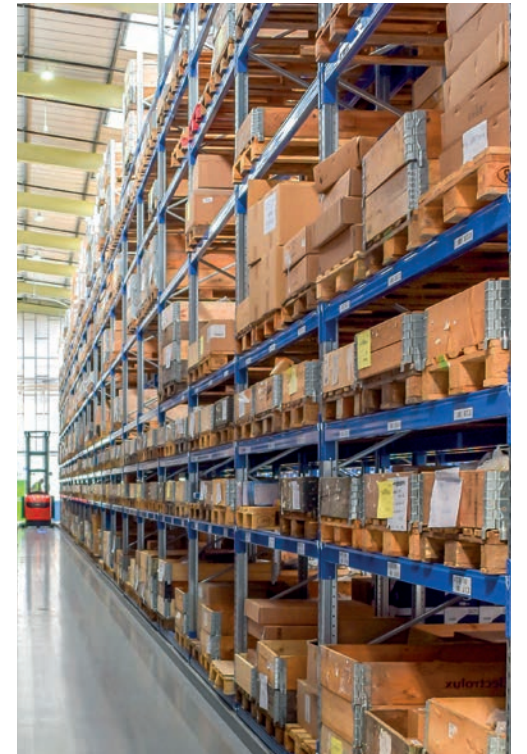

Please contact us on
0800 008 6861 or
enquiries@polstore.co.uk
for any requirements
you may have.

Secure Storage Solution

FOR RESEARCH CENTRE'S WORKSHOP



Polstore's clients receive the same exceptional service and advice but the end result will be bespoke to your workspace.

Nuclear Advanced Manufacturing Research Centre (NAMRC), part of the University of Sheffield, are at the forefront of innovation and manufacturing development. The open facilities and services at NAMRC mean security is a top priority. A variety of workspaces were created to suit the working arrangements required by the different teams.

Here we created an 'L' section for each working module with workshop storage cabinets and heavy-duty worktops, ideal for a more structured workspace.

The workshop storage area for product development was inspired by the U-shape layout we use in Formula 1 motorsport workshop fit outs, this larger space was fitted with mobile cabinets on castors so they can be easily moved around.

Over £35 million worth of state-of-the-art manufacturing equipment is stored onsite. We retrofitted the workshop drawer and cupboard units with an intelligent smart key and access control system, eLOQ. This inexpensive but highly secure system offers a greater degree of flexibility and auditability.

The rented workspaces for research and product development were fully controlled by the eLOQ system. NAMRC know exactly where their equipment is, they can control who has access to it and when. The workshop drawer cabinets were also fitted out with plastazote foam inlays which help to identify misplaced tools, as well as keep them protected when stored.

Whether you have one room or a whole workshop to optimise, our team at Polstore can give you workshop storage solutions which deliver to your needs, today, tomorrow and in the future.

If you are on the lookout for workshop storage solutions – call us on 0800 008 6861 or email enquiries@polstore.co.uk for advice on how to optimise your workshop.

One single electronic key can open up to 3,000 padlocks, cylinders and camlocks

eLOQ is an intelligent smart key and access control system which has been designed to offer not only high security, but also offers a greater degree of flexibility and audibility not otherwise possible with traditional access solutions.

Although eLOQ locks are electronic, they contain no batteries and do not require wiring. With a wide range of easily retro-fittable cylinders and padlocks available, introducing eLOQ means you can implement incredibly flexible levels of remote access control to your organisation.

With a collection of advance features such as; audit trails of key usage, the ability to disable lost keys and electronic rekeying & scheduling, eLOQ embraces modern technologies and innovations to bring a unique control for the protection of goods and assets.

The eLOQ Access Control system operates in much the same way as a traditional lock & key set-up, but with the ability to personalise unique time and date restrictions for each user. This means you have complete control over which locks can be accessed and when.



eLOQ Key

Central to the eLOQ access control system is the individual User Keys; each of which can be programmed to each users own specific schedule and access requirements.



eLOQ Locks

With a wide range of different retro-fittable cylinders and padlocks available for a range of different environments, our locks are quick & easy to change and install.



eLOQ Key Readers

Required for scheduling and programming locks & keys, the eLOQ readers take many different forms from Wall-Readers, Computer Interfaces and Mobile Apps.



eLOQ Software

Easily update and amend user schedules using our secure, cloud-based software which has been designed to be user-friendly. Run complete audit reports on locks and keys to examine previous access activities.

0800 008 6861
www.polstore.co.uk
enquiries@polstore.co.uk
f t i / polstoreuk



PRODUCT INDEX

PLASTIC UNIBOX	18
COMBO DRAWER CABINETS	22
DRAWER CABINETS	30
COMBO WORKBENCHES	48
WORKBENCHES	52
ANTI-FATIGUE MATTING	62
ROLLER SHUTTER CABINETS	63
HOOKS FOR PERFORATED BACK PANELS	64
COMPUTER CABINETS	68
CNC STORAGE & TRANSPORT	74
STORAGE CUPBOARDS	76
TROLLEYS SERIES 77	78



Scan here to see
our complete index
of products!

9 COMPARTMENTS



Part. No.
S99-60907 **£23**
UNIBOX: 600x51x77 mm h
Compartments: 59x45x65 mm h

6 COMPARTMENTS



Part. No.
S99-60607 **£26**
UNIBOX: 600x91x112 mm h
Compartment: 87x66x100 mm h

5 COMPARTMENTS



Part. No.
S99-60507 **£29**
UNIBOX: 600x133x164 mm h
Compartments: 113x100x150 mm h

4 COMPARTMENTS



Part. No.
S99-60407 **£35**
UNIBOX: 600x170x206 mm h
Compartments: 142x130x194 mm h

3 COMPARTMENTS



Part. No.
S99-60307 **£43**
UNIBOX: 600x200x240 mm h
Compartments: 190x146x225 mm h

UNIBOX WALL RACKS



Part. No.	H	
S99-62157/07	1500 mm	£86
S99-62177/07	1750 mm	£92
S99-62197/07	1950 mm	£99

600x25x height mm

UNIBOX FREE STANDING RACKS



Part. No.	H	
S99-63157/07	1500 mm	£131
S99-63177/07	1750 mm	£134
S99-63197/07	1950 mm	£141

600x325x height mm

UNIBOX FREE STANDING RACKS 62 Compartments

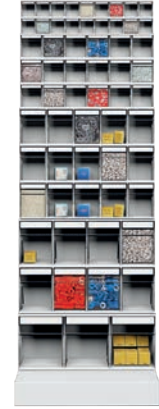

Part. No.
S99-63177-03/07 **£374**
600x325x1750 mm h
2 Unibox 9 Compartments
3 Unibox 6 Compartments
3 Unibox 5 Compartments
2 Unibox 4 Compartments
1 Unibox 3 Compartments

UNIBOX FREE STANDING RACKS 117 Compartments



Part. No.
S99-63197-01/07 **£395**
600x325x1950 mm h
6 Unibox 9 Compartments
9 Unibox 6 Compartments
1 Unibox 5 Compartments
1 Unibox 4 Compartments

UNIBOX FREE STANDING RACKS 66 Compartments



Part. No.
S99-63197-03/07 **£388**
600x325x1950 mm h
2 Unibox 9 Compartments
3 Unibox 6 Compartments
3 Unibox 5 Compartments
3 Unibox 4 Compartments
1 Unibox 3 Compartments

UNIBOX FREE STANDING RACKS 70 Compartments



Part. No.
S99-63197-05/07 **£366**
600x325x1950 mm h
7 Unibox 6 Compartments
4 Unibox 5 Compartments
2 Unibox 4 Compartments

PLASTIC UNIBOX

UNIBOX TROLLEY

88 Compartments



Part. No.
S99-64147-01/07 **£633**
660x750x1365 mm h
2 Unibox 9 Compartments
6 Unibox 6 Compartments
4 Unibox 5 Compartments
2 Unibox 4 Compartments
2 Unibox 3 Compartments

UNIBOX TROLLEY

66 Compartments



Part. No.
S99-64147-03/07 **£633**
660x750x1365 mm h
4 Unibox 6 Compartments
4 Unibox 5 Compartments
4 Unibox 4 Compartments
2 Unibox 3 Compartments

UNIBOX TROLLEY

84 Compartments



Part. No.
S99-64147-07/07 **£626**
660x750x1365 mm h
6 Unibox 6 Compartments
8 Unibox 5 Compartments
2 Unibox 4 Compartments

UNIBOX TROLLEY

70 Compartments



Part. No.
S99-64147-09/07 **£590**
660x750x1365 mm h
14 Unibox 5 Compartments

UNIBOX TROLLEY

120 Compartments



Part. No.
S99-64147-11/07 **£626**
660x750x1365 mm h
20 Unibox 6 Compartments

VERTICAL SPACE SAVER

720 Compartments



Part. No.
S99-85427-02/07 **£3438**
1073x707x2000 mm h
120 Unibox 6 Compartments
KG 150 Kg

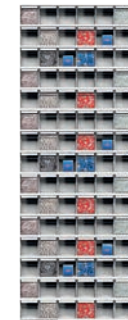

8 pcs.
15 Unibox 6 Compartments

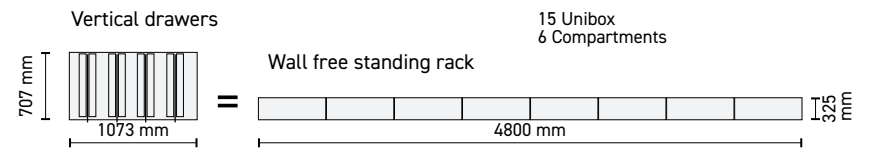

VERTICAL SPACE SAVER

344 Compartments



Part. No.
S99-85427-06/07 **£2737**
1073x707x2000 mm h
30 Unibox 6 Compartments
20 Unibox 5 Compartments
16 Unibox 4 Compartments
KG 150 Kg

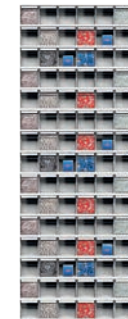

2 pcs.
15 Unibox 6 Compartments



2 pcs.
10 Unibox 5 Compartments



2 pcs.
8 Unibox 4 Compartments

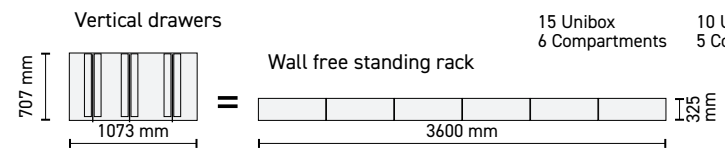

VERTICAL SPACE SAVER

480 Compartments



Part. No.
S99-87827-04/07 **£3382**
1481x707x2000 mm h
30 Unibox 6 Compartments
60 Unibox 5 Compartments
KG 150 Kg



2 pcs.
15 Unibox 6 Compartments



6 pcs.
10 Unibox 5 Compartments

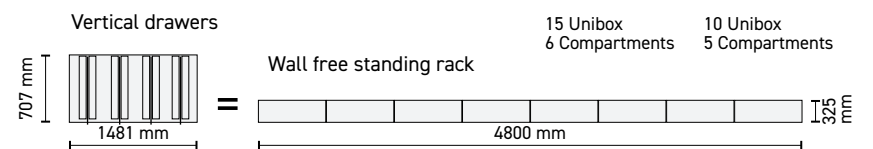

COMBO DRAWER CABINETS

£800

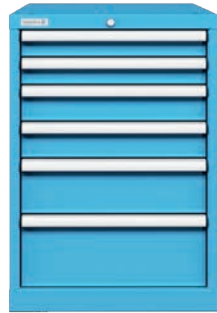

02
75 S
75 S
100 S
100 S
150 S
200 S

S111-20800-02/XX

Cabinet 27x27 Eh with 6 Drawers - normal extension
564x572x800 mm h
PARTITIONING MATERIAL INCLUDED

100 Kg

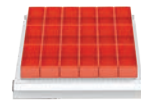

PLASTIC BOXES Qty 1
18 Plastic boxes 150x75 mm
For front height: 75 mm

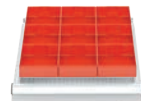

PLASTIC BOXES Qty 1
9 Plastic boxes 150x150 mm
For front height: 75 mm

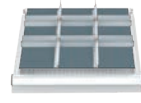

SLOTTED PARTITIONS Qty 2
2 Slotted partitions 27 Eh - 459 mm
6 Aluminium dividers 9 Eh - 149 mm
For front height: 100 mm

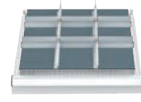

SLOTTED PARTITIONS Qty 1
2 Slotted partitions 27 Eh - 459 mm
6 Aluminium dividers 9 Eh - 149 mm
For front height: 150 mm

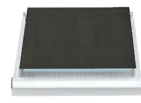

ANTI-SLIP Qty 1
Perforated mat

£795

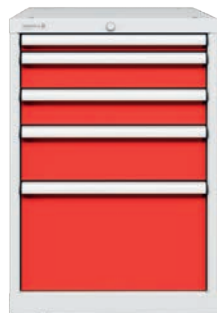

01
50 S
100 S
100 S
150 S
300 S

S110-20800-01/XX

Cabinet 27x36 Eh with 5 Drawers - normal extension
564x725x800 mm h
PARTITIONING MATERIAL INCLUDED

100 Kg

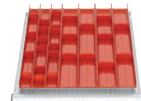

TROUGHS Qty 1
8 Troughs 2 grooves Ø 70 mm
10 Troughs dividers
4 Troughs 3 grooves Ø 45 mm
20 Troughs dividers
For front height: 50 mm

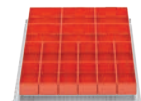

PLASTIC BOXES Qty 1
12 Plastic boxes 150x75 mm
6 Plastic boxes 150x150 mm
For front height: 100 mm

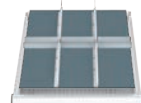

SLOTTED PARTITIONS Qty 1
2 Slotted partitions 36 Eh - 612 mm
3 Aluminium dividers 9 Eh - 149 mm
For front height: 100 mm

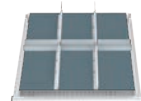

SLOTTED PARTITIONS Qty 1
2 Slotted partitions 36 Eh - 612 mm
3 Aluminium dividers 9 Eh - 149 mm
For front height: 150 mm

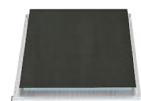

ANTI-SLIP Qty 1
Perforated mat

COLOUR

When ordering, please complete the article number by adding the desired two-digit colour code.

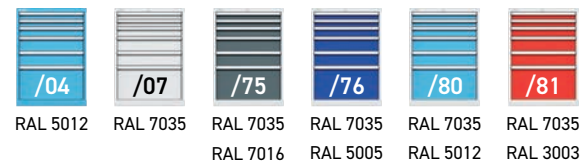

£1446

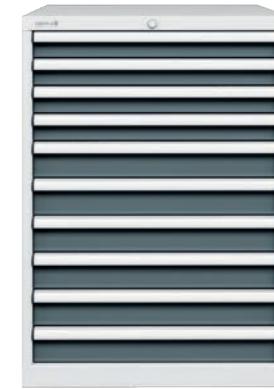

32
75 T
75 T
75 T
75 T
100 T
100 T
100 T
100 T
100 T
100 T
100 T

S111-31000-32/XX

Cabinet 36x27 Eh with 10 Drawers - full extension
717x572x1000 mm h
PARTITIONING MATERIAL INCLUDED

200 Kg

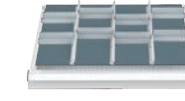

SLOTTED PARTITIONS Qty 4
3 Slotted partitions 27 Eh - 459 mm
8 Aluminium dividers 9 Eh - 149 mm
For front height: 75 mm

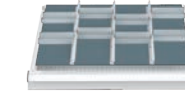

SLOTTED PARTITIONS Qty 4
3 Slotted partitions 27 Eh - 459 mm
8 Aluminium dividers 9 Eh - 149 mm
For front height: 100 mm



ANTI-SLIP Qty 2
Perforated mat

£1418



28
100 T
100 T
100 T
100 T
100 T
100 T
100 T
100 T
100 T

S110-31000-28/XX

Cabinet 36x36 Eh with 9 Drawers - full extension
717x725x1000 mm h
PARTITIONING MATERIAL INCLUDED

200 Kg

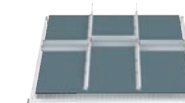

SLOTTED PARTITIONS Qty 9
2 Slotted partitions 36 Eh - 612 mm
3 Aluminium dividers 12 Eh - 200 mm
For front height: 100 mm

COLOUR

When ordering, please complete the article number by adding the desired two-digit colour code.

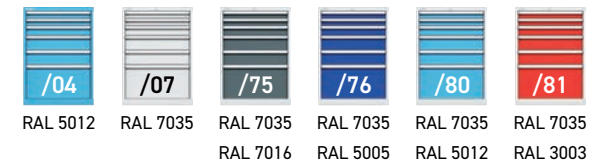

COMBO DRAWER CABINETS

£1236

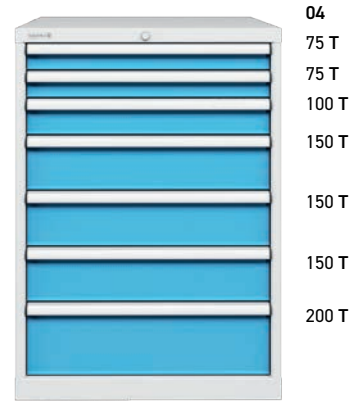

S110-31000-04/XX

Cabinet 36x36 Eh with 7 Drawers - full extension
717x725x1000 mm h
PARTITIONING MATERIAL INCLUDED

200 Kg

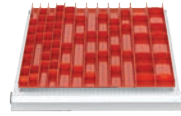

TROUGHS Qty 1
4 Troughs 2 grooves Ø 70 mm
10 Troughs dividers
8 Troughs 3 grooves Ø 45 mm
20 Troughs dividers
4 Troughs 4 grooves Ø 33 mm
30 Troughs dividers
For front height: 75 mm

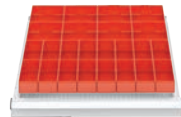

PLASTIC BOXES Qty 1
16 Plastic boxes 150x75 mm
8 Plastic boxes 150x150 mm
For front height: 75 mm

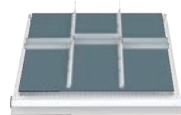

SLOTTED PARTITIONS Qty 1
2 Slotted partitions 36 Eh - 612 mm
3 Aluminium dividers 12 Eh - 200 mm
For front height: 100 mm

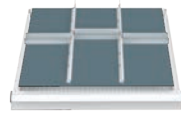

SLOTTED PARTITIONS Qty 3
2 Slotted partitions 36 Eh - 612 mm
3 Aluminium dividers 12 Eh - 200 mm
For front height: 150 mm



ANTI-SLIP Qty 1
Perforated mat

£1229



S111-40850-16/XX

Cabinet 45x27 Eh with 7 Drawers - full extension
870x572x850 mm h
PARTITIONING MATERIAL INCLUDED

200 Kg

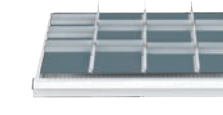

SLOTTED PARTITIONS Qty 2
3 Slotted partitions 27 Eh - 459 mm
2 Aluminium dividers 9 Eh - 149 mm
7 Aluminium dividers 12 Eh - 200 mm
For front height: 75 mm

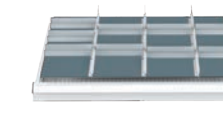

SLOTTED PARTITIONS Qty 2
3 Slotted partitions 27 Eh - 459 mm
2 Aluminium dividers 9 Eh - 149 mm
7 Aluminium dividers 12 Eh - 200 mm
For front height: 100 mm



ANTI-SLIP Qty 3
Perforated mat

£1489

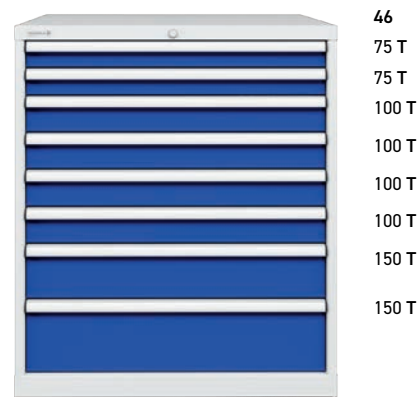

S110-41000-46/XX

Cabinet 45x36Eh with 8 Drawers - full extension
870x725x1000 mm h
PARTITIONING MATERIAL INCLUDED

200 Kg

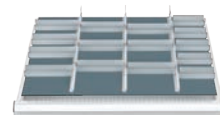

SLOTTED PARTITIONS Qty 2
3 Slotted partitions 36 Eh - 612 mm
5 Aluminium dividers 9 Eh - 149 mm
10 Aluminium dividers 12 Eh - 200 mm
For front height: 75 mm

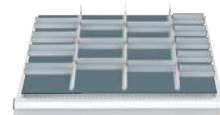

SLOTTED PARTITIONS Qty 4
3 Slotted partitions 36 Eh - 612 mm
5 Aluminium dividers 9 Eh - 149 mm
10 Aluminium dividers 12 Eh - 200 mm
For front height: 100 mm



ANTI-SLIP Qty 2
Perforated mat

£1670



S111-51000-34/XX

Cabinet 54x27 Eh with 9 Drawers - full extension
1023x572x1000 mm h
PARTITIONING MATERIAL INCLUDED

200 Kg

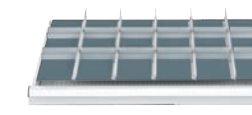

SLOTTED PARTITIONS Qty 9
5 Slotted partitions 27 Eh - 459 mm
12 Aluminium dividers 9 Eh - 149 mm
For front height: 100 mm

COLOUR

When ordering, please complete the article number by adding the desired two-digit colour code.

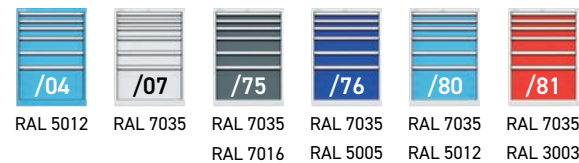

COLOUR

When ordering, please complete the article number by adding the desired two-digit colour code.

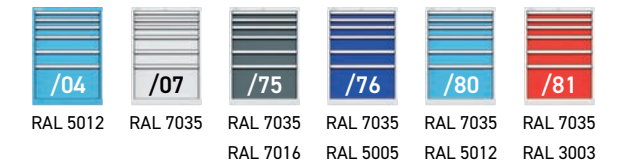

COMBO DRAWER CABINETS

£1755

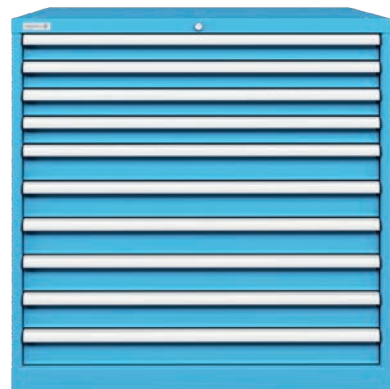

32
75 T
75 T
75 T
75 T
100 T
100 T
100 T
100 T
100 T
100 T
100 T

S111-51000-32/XX

Cabinet 54x27 Eh with 10 Drawers - full extension
1023x572x1000 mm h
PARTITIONING MATERIAL INCLUDED

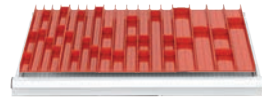

TROUGHS Qty 1
6 Troughs 2 grooves Ø 70 mm
6 Troughs dividers
6 Troughs 3 grooves Ø 45 mm
10 Troughs dividers
6 Troughs 4 grooves Ø 33 mm
15 Troughs dividers
For front height: 50 mm



PLASTIC BOXES Qty 1
12 Plastic boxes 150x75 mm
12 Plastic boxes 150x150 mm
For front height: 75 mm

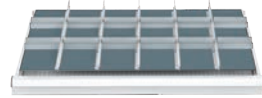

SLOTTED PARTITIONS Qty 2
5 Slotted partitions 27 Eh - 459 mm
12 Aluminium dividers 9 Eh - 149 mm
For front height: 75 mm

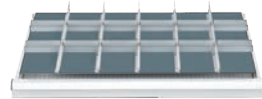

SLOTTED PARTITIONS Qty 4
5 Slotted partitions 27 Eh - 459 mm
12 Aluminium dividers 9 Eh - 149 mm
For front height: 100 mm



ANTI-SLIP Qty 2
Perforated mat

£1559

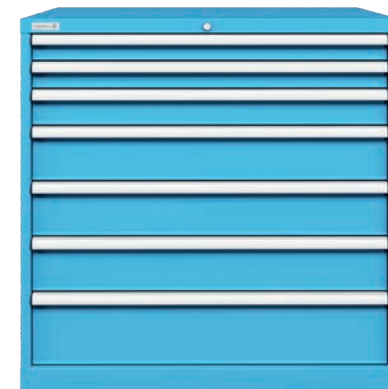

04
75 T
75 T
100 T
150 T
150 T
150 T
200 T

S110-51000-06/XX

Cabinet 54x36 Eh with 7 Drawers - full extension
1023x725x1000 mm h
PARTITIONING MATERIAL INCLUDED

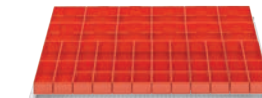

PLASTIC BOXES Qty 1
20 Plastic boxes 75x75 mm
14 Plastic boxes 150x75 mm
12 Plastic boxes 150x150 mm
For front height: 75 mm

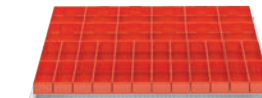

PLASTIC BOXES Qty 1
24 Plastic boxes 150x75 mm
12 Plastic boxes 150x150 mm
For front height: 75 mm

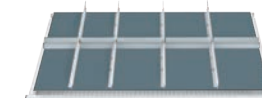

SLOTTED PARTITIONS Qty 1
4 Slotted partitions 36 Eh - 612 mm
2 Aluminium dividers 9 Eh - 149 mm
3 Aluminium dividers 12 Eh - 200 mm
For front height: 100 mm

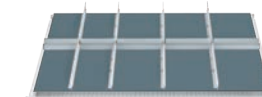

SLOTTED PARTITIONS Qty 3
4 Slotted partitions 36 Eh - 612 mm
2 Aluminium dividers 9 Eh - 149 mm
3 Aluminium dividers 12 Eh - 200 mm
For front height: 150 mm



ANTI-SLIP Qty 1
Perforated mat

£1712



34
100 T
100 T
100 T
100 T
100 T
100 T
100 T
100 T
100 T
100 T

S110-51000-34/XX

Cabinet 54x36 Eh with 9 Drawers - full extension
1023x725x1000 mm h
PARTITIONING MATERIAL INCLUDED

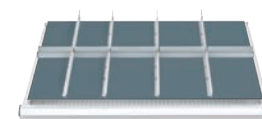

SLOTTED PARTITIONS Qty 9
4 Slotted partitions 36 Eh - 612 mm
2 Aluminium dividers 9 Eh - 149 mm
3 Aluminium dividers 12 Eh - 200 mm
For front height: 100 mm

COLOUR

When ordering, please complete the article number by adding the desired two-digit colour code.

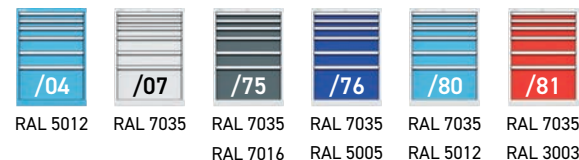

COLOUR

When ordering, please complete the article number by adding the desired two-digit colour code.

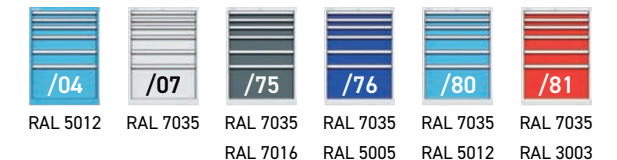

COMBO DRAWER CABINETS

£1362



S10-30850-121/XX

HOOKS

pg. 52



Cabinet 36x36 Eh with 5 Drawers:
 1 x 100 T
 3 x 150 T
 1 x 200 T
 1 Perforated panel
 Multiplex worktop 717x725x40 mm h
 1 Base plinth 100 mm h
 Dimensions: 717x745x990/1560 mm h
WITHOUT HOOKS

 **LOAD CAPACITY (DRAWER)**
 KG 200 Kg.

£1839



S10-39870C-06/XX



Cabinet 36x36 Eh with 8 Drawers:
 4 x 75 T
 3 x 100 T
 1 x 150 T
 4 Castors
 4 UNIBOX 5 Compartments and 1 Rack
 Multiplex worktop 717x725x40 mm h
 Dimensions: 957x725x934 mm h

 **LOAD CAPACITY (DRAWER)**
 KG 70 Kg.

COLOUR

When ordering, please complete the article number by adding the desired two-digit colour code.

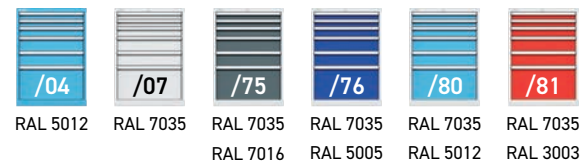

DRAWER CABINETS

411x572 mm - 18x27 Eh

H 383 mm 3 Drawers



Art. Nr. 75 **£528**
S11-10380-13/XX

H 383 mm 3 Drawers



Art. Nr. 75 **£556**
S11-10380-14/XX

H 533 mm 3 Drawers



Art. Nr. 75 **£584**
S11-10530-10/XX

H 700 mm 5 Drawers

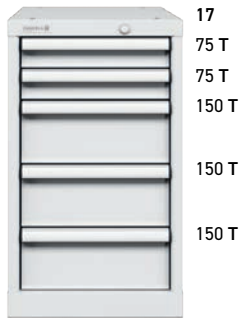

Art. Nr. 75 **£780**
S11-10700-17/XX

H 705 mm 4 Drawers



Art. Nr. 75 **£794**
S11-19540A-14/XX



H 872 mm 5 Drawers

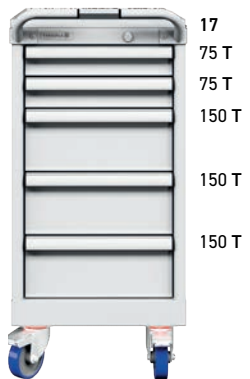

Art. Nr. 75 **£962**
S11-19710A-17/XX

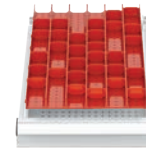

TROUGHS

For front height	Part. No.	
50 mm and higher	S08-10003	£34
6 Troughs 3 grooves Ø 45 mm		
30 Trough dividers		

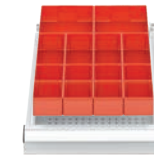

PLASTIC BOXES

For front height	Part. No.	
50 mm	S08-11605	£31
75 mm	S08-11607	£33
8 Plastic boxes 75x75 mm		
4 Plastic boxes 150x75 mm		
2 Plastic boxes 150x150 mm		

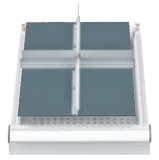

SLOTTED PARTITIONS

For front height	Part. No.	
75 mm	S08-13007	£19
100-125 mm	S08-13010	£19
150 mm	S08-13015	£23
200-250 mm	S08-13020	£24
1 Slotted partition 27 Eh - 459 mm		
2 Aluminium dividers 9 Eh - 149 mm		

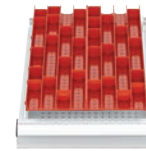

TROUGHS

For front height	Part. No.	
50 mm and higher	S08-10004	£38
6 Troughs 4 grooves Ø 33 mm		
40 Trough dividers		

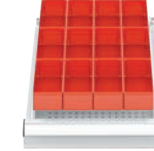

PLASTIC BOXES

For front height	Part. No.	
50 mm	S08-11105	£29
75 mm	S08-11107	£30
100-125 mm	S08-11110	£40
12 Plastic boxes 150x75 mm		

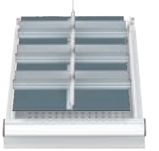

SLOTTED PARTITIONS

For front height	Part. No.	
75 mm	S08-13107	£23
100-125 mm	S08-13110	£27
150 mm	S08-13115	£30
200-250 mm	S08-13120	£34
1 Slotted partition 27 Eh - 459 mm		
6 Aluminium dividers 9 Eh - 149 mm		

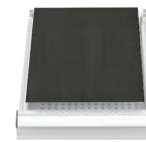

ANTI-SLIP PERFORATED MAT

	Part. No.	
Kit 4 pcs.	S04-30804-04	£58
Dimensions: 300x450x3 mm h		
Colour: Black		

COLOUR

When ordering, please complete the article number by adding the desired two-digit colour code.

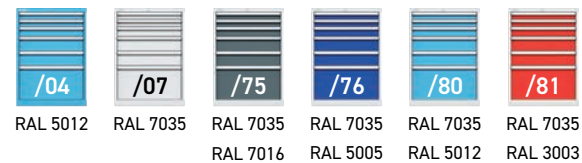

DRAWER CABINETS

411x725 mm - 18x36 Eh

H 383 mm 3 Drawers



Art. Nr. 75 **£535**
S10-10380-13/XX

H 383 mm 3 Drawers



Art. Nr. 75 **£563**
S10-10380-14/XX

H 533 mm 3 Drawers



Art. Nr. 75 **£591**
S10-10530-10/XX

H 700 mm 5 Drawers

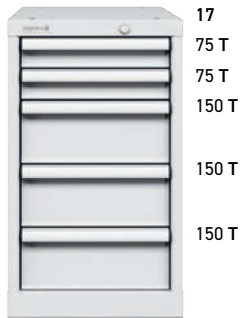

Art. Nr. 75 **£787**
S10-10700-17/XX

H 705 mm 4 Drawers



Art. Nr. 75 **£801**
S10-19540A-14/XX

H 872 mm 5 Drawers

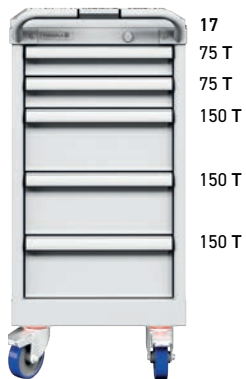

Art. Nr. 75 **£970**
S10-19710A-17/XX

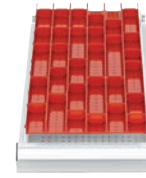

TROUGHS

For front height	Part. No.	
50 mm and higher	S07-10003	£38
8 Troughs 3 grooves Ø 45 mm		
30 Trough dividers		

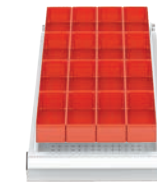

PLASTIC BOXES

For front height	Part. No.	
50 mm	S07-11105	£34
75 mm	S07-11107	£37
100-125 mm	S07-11110	£50
16 Plastic boxes 150x75 mm		

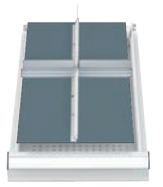

SLOTTED PARTITIONS

For front height	Part. No.	
75 mm	S07-13007	£19
100-125 mm	S07-13010	£22
150 mm	S07-13015	£23
200-250 mm	S07-13020	£26
1 Slotted partition 36 Eh - 612 mm		
2 Aluminium dividers 9 Eh - 149 mm		

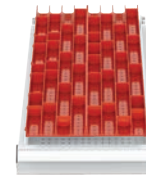

TROUGHS

For front height	Part. No.	
50 mm and higher	S07-10004	£43
8 Troughs 4 grooves Ø 33 mm		
40 Trough dividers		

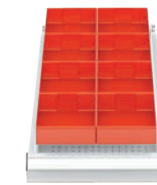

PLASTIC BOXES

For front height	Part. No.	
50 mm	S07-11205	£31
75 mm	S07-11207	£33
100-125 mm	S07-11210	£37
8 Plastic boxes 150x150 mm		

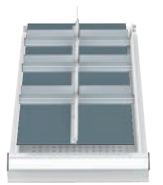

SLOTTED PARTITIONS

For front height	Part. No.	
75 mm	S07-13107	£23
100-125 mm	S07-13110	£27
150 mm	S07-13115	£31
200-250 mm	S07-13120	£36
1 Slotted partition 36 Eh - 612 mm		
6 Aluminium dividers 9 Eh - 149 mm		



ANTI-SLIP PERFORATED MAT

	Part. No.	
Kit 4 pcs.	S04-30814-04	£65
Dimensions: 300x600x3 mm h		
Colour: Black		

COLOUR

When ordering, please complete the article number by adding the desired two-digit colour code.

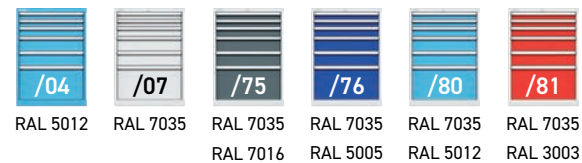

DRAWER CABINETS

564x572 mm - 27x27 Eh

H 800 mm 5 Drawers

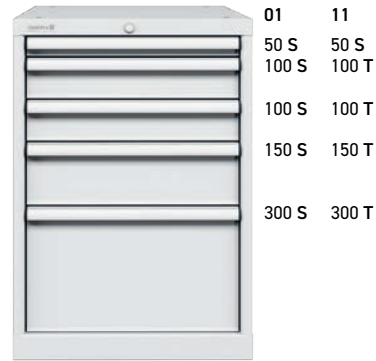

01 11
50 S 50 S
100 S 100 T
100 S 100 T
150 S 150 T
300 S 300 T

Art. Nr.	KG	
S11-20800-01/XX	100	£626
S11-20800-11/XX	100	£731

H 800 mm 6 Drawers



02 12
75 S 75 T
75 S 75 T
100 S 100 T
100 S 100 T
150 S 150 T
200 S 200 T

Art. Nr.	KG	
S11-20800-02/XX	100	£672
S11-20800-12/XX	100	£829

H 800 mm 8 Drawers



19
75 T
75 T
75 T
75 T
100 T
100 T
100 T
100 T
100 T
100 T

Art. Nr.	KG	
S11-20800-19/XX	100	£984

H 705 mm 4 Drawers



18
50 S
100 T
100 T
200 T

Art. Nr.	KG	
S11-29540A-18/XX	75	£780

H 972 mm 6 Drawers



12
75 T
75 T
100 T
100 T
150 T
200 T

Art. Nr.	KG	
S11-29810A-12/XX	75	£1012

H 850 mm 7 Drawers



03 13
75 S 75 T
75 S 75 T
100 S 100 T
100 S 100 T
100 S 100 T
150 S 150 T
150 S 150 T

Art. Nr.	KG	
S11-20850-03/XX	100	£731
S11-20850-13/XX	100	£914

H 850 mm 8 Drawers



22
75 T
75 T
75 T
75 T
100 T
100 T
100 T
100 T
150 T
150 T

Art. Nr.	KG	
S11-20850-22/XX	100	£998

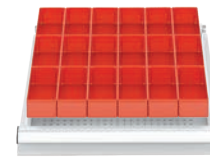

PLASTIC BOXES

For front height	Part. No.	
50 mm	S08-21105	£37
75 mm	S08-21107	£40
100-125 mm	S08-21110	£54
18 Plastic boxes 150x75 mm		

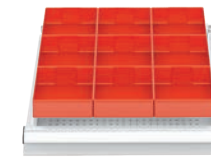

PLASTIC BOXES

For front height	Part. No.	
50 mm	S08-21205	£33
75 mm	S08-21207	£34
100-125 mm	S08-21210	£38
9 Plastic boxes 150x150 mm		

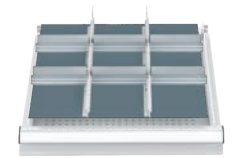

SLOTTED PARTITIONS

For front height	Part. No.	
50 mm	S08-23205	£27
75 mm	S08-23207	£31
100-125 mm	S08-23210	£37
150 mm	S08-23215	£43
200-250 mm	S08-23220	£50
300 mm	S08-23230	£61

2 Slotted partitions 27 Eh - 459 mm
6 Aluminium dividers 9 Eh - 149 mm



ANTI-SLIP PERFORATED MAT

Kit 4 pcs.	Part. No.	
	S04-30824-04	£61
Dimensions: 450x450x3 mm h		
Colour: Black		

COLOUR

When ordering, please complete the article number by adding the desired two-digit colour code.

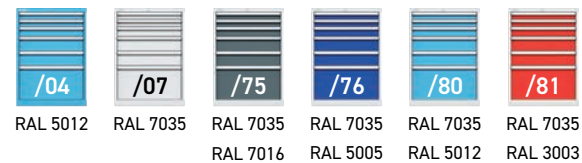

DRAWER CABINETS

564x725 mm - 27x36 Eh

H 800 mm 5 Drawers



01	11
50 S	50 S
100 S	100 T
100 S	100 T
150 S	150 T
150 S	150 T
300 S	300 T

Art. Nr.	KG	Price
S10-20800-01/XX	100	£654
S10-20800-11/XX	100	£759

H 800 mm 6 Drawers



02	12
75 S	75 T
75 S	75 T
100 S	100 T
100 S	100 T
150 S	150 T
150 S	150 T
200 S	200 T

Art. Nr.	KG	Price
S10-20800-02/XX	100	£703
S10-20800-12/XX	100	£871

H 800 mm 7 Drawers



04	14
50 S	50 S
75 S	75 T
75 S	75 T
100 S	100 T
100 S	100 T
150 S	150 T
150 S	150 T

Art. Nr.	KG	Price
S10-20800-04/XX	100	£745
S10-20800-14/XX	100	£928

H 872 mm 5 Drawers



02	12
75 S	75 T
75 S	75 T
100 S	100 T
150 S	150 T
150 S	150 T
200 S	200 T

Art. Nr.	KG	Price
S10-29710A-02/XX	100	£829
S10-29710A-12/XX	100	£956



H 972 mm 5 Drawers



01	11
50 S	50 S
100 S	100 T
100 S	100 T
150 S	150 T
150 S	150 T
300 S	300 T

Art. Nr.	KG	Price
S10-29810A-01/XX	100	£871
S10-29810A-11/XX	100	£970



H 972 mm 6 Drawers



02	12
75 S	75 T
75 S	75 T
100 S	100 T
100 S	100 T
150 S	150 T
150 S	150 T
200 S	200 T

Art. Nr.	KG	Price
S10-29810A-02/XX	100	£928
S10-29810A-12/XX	100	£1075



H 850 mm 5 Drawers



09	19
100 S	100 T
100 S	100 T
150 S	150 T
150 S	150 T
200 S	200 T
200 S	200 T

Art. Nr.	KG	Price
S10-20850-09/XX	100	£675
S10-20850-19/XX	100	£829

H 850 mm 7 Drawers



03	13
75 S	75 T
75 S	75 T
100 S	100 T
100 S	100 T
100 S	100 T
150 S	150 T
150 S	150 T
150 S	150 T

Art. Nr.	KG	Price
S10-20850-03/XX	100	£780
S10-20850-13/XX	100	£990



ANTI-SLIP PERFORATED MAT

Part. No.	Price
Kit 4 pcs. S04-30834-04	£68

Dimensions: 450x600x3 mm h
Colour: Black

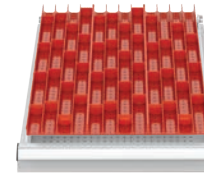

TROUGHS

For front height	Part. No.	Price
50 mm and higher	S07-20004	£54

12 Troughs 4 grooves Ø 33 mm
50 Trough dividers

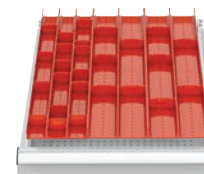

TROUGHS

For front height	Part. No.	Price
50 mm and higher	S07-20023	£47

8 Troughs 2 grooves Ø 70 mm
10 Trough dividers
4 Troughs 3 grooves Ø 45 mm
20 Trough dividers

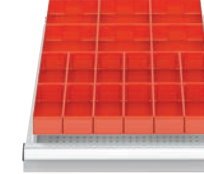

PLASTIC BOXES

For front height	Part. No.	Price
50 mm	S07-21405	£43
75 mm	S07-21407	£47
100-125 mm	S07-21410	£58

12 Plastic boxes 150x75 mm
6 Plastic boxes 150x150 mm

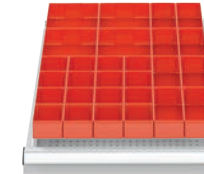

PLASTIC BOXES

For front height	Part. No.	Price
50 mm	S07-21505	£52
75 mm	S07-21507	£55

16 Plastic boxes 75x75 mm
8 Plastic boxes 150x75 mm
4 Plastic boxes 150x150 mm

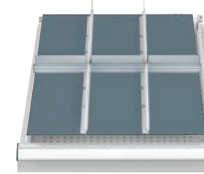

SLOTTED PARTITIONS

For front height	Part. No.	Price
75 mm	S07-23107	£26
100-125 mm	S07-23110	£30
150 mm	S07-23115	£31
200-250 mm	S07-23120	£36

2 Slotted partitions 36 Eh - 612 mm
3 Aluminium dividers 9 Eh - 149 mm

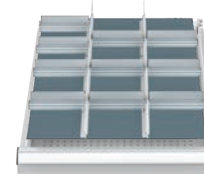

SLOTTED PARTITIONS

For front height	Part. No.	Price
50 mm	S07-23205	£30
75 mm	S07-23207	£31
100-125 mm	S07-23210	£38
150 mm	S07-23215	£45

2 Slotted partitions 36 Eh - 612 mm
10 Aluminium dividers 9 Eh - 149 mm

COLOUR

When ordering, please complete the article number by adding the desired two-digit colour code.

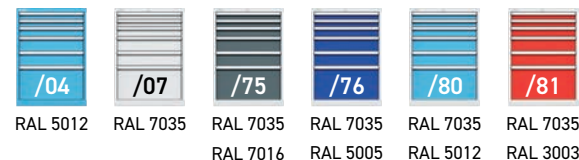

DRAWER CABINETS

717x572 mm - 36x27 Eh

H 850 mm 8 Drawers



06
75 T
75 T
75 T
75 T
100 T
100 T
100 T
100 T

Art. Nr.  **£1054**
S11-30850-06/XX 200

H 1000 mm 6 Drawers



15
150 T
150 T
150 T
150 T
150 T
150 T

Art. Nr.  **£914**
S11-31000-15/XX 200

H 1000 mm 7 Drawers



04
75 T
75 T
100 T
150 T
150 T
150 T
200 T

Art. Nr.  **£998**
S11-31000-04/XX 200

H 1000 mm 8 Drawers



12
100 T
100 T
100 T
100 T
100 T
100 T
100 T
100 T
100 T
100 T
100 T

Art. Nr.  **£1152**
S11-31000-12/XX 200

H 1000 mm 9 Drawers



24
75 T
75 T
75 T
75 T
100 T
100 T
100 T
100 T
150 T
150 T

Art. Nr.  **£1166**
S11-31000-24/XX 200

H 1000 mm 10 Drawers



32
75 T
75 T
75 T
75 T
100 T
100 T
100 T
100 T
100 T
100 T
100 T
100 T

Art. Nr.  **£1236**
S11-31000-32/XX 200

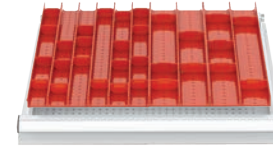

TROUGHS

For front height	Part. No.	
50 mm and higher	S08-30023	£47
6 Troughs 2 grooves Ø70 mm		
10 Trough dividers		
6 Troughs 3 grooves Ø45 mm		
20 Trough dividers		

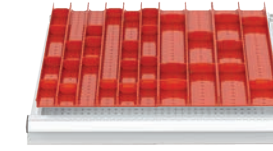

TROUGHS

For front height	Part. No.	
50 mm and higher	S08-30034	£54
3 Troughs 3 grooves Ø 45 mm		
12 Trough dividers		
9 Troughs 4 grooves Ø 33 mm		
36 Trough dividers		

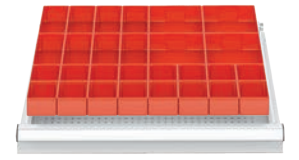

PLASTIC BOXES

For front height	Part. No.	
75 mm	S07-21407	£47
100-125 mm	S07-21410	£58
12 Plastic boxes 150x75 mm		
6 Plastic boxes 150x150 mm		

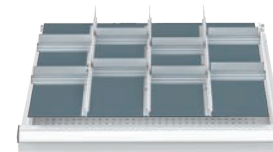

SLOTTED PARTITIONS

For front height	Part. No.	
75 mm	S08-33307	£34
100-125 mm	S08-33310	£40
150 mm	S08-33315	£47
3 Slotted partitions 27 Eh - 459 mm		
8 Aluminium dividers 9 Eh - 149 mm		

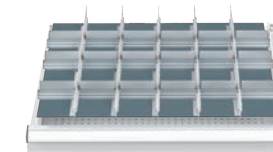

SLOTTED PARTITIONS

For front height	Part. No.	
75 mm	S08-33507	£51
100-125 mm	S08-33510	£61
150 mm	S08-33515	£68
5 Slotted partitions 27 Eh - 459 mm		
18 Aluminium dividers 6 Eh - 98 mm		



ANTI-SLIP PERFORATED MAT

	Part. No.	
Kit 4 pcs.	S04-30834-04	£68
Dimensions: 450x600x3 mm h		
Colour: Black		

COLOUR

When ordering, please complete the article number by adding the desired two-digit colour code.

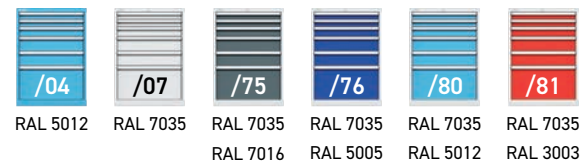

DRAWER CABINETS

717x725 mm - 36x36 Eh

H 1000 mm 6 Drawers



15
150 T
150 T
150 T
150 T
150 T
150 T

Art. Nr.	KG	Price
S10-31000-15/XX	200	£991

H 1000 mm 7 Drawers



03 04
75 S 75 T
75 S 75 T
100 S 100 T
150 S 150 T
150 S 150 T
150 S 150 T
200 S 200 T

Art. Nr.	KG	Price
S10-31000-03/XX	100	£857
S10-31000-04/XX	200	£1054

H 1000 mm 8 Drawers



11 12
75 S 75 T
75 S 75 T
100 S 100 T
100 S 100 T
100 S 100 T
100 S 100 T
150 S 150 T
200 S 200 T

Art. Nr.	KG	Price
S10-31000-11/XX	100	£928
S10-31000-12/XX	200	£1152

H 1000 mm 9 Drawers



17 18
75 S 75 T
75 S 75 T
75 S 75 T
75 S 75 T
100 S 100 T
100 S 100 T
100 S 100 T
100 S 100 T
150 S 150 T
150 S 150 T

Art. Nr.	KG	Price
S10-31000-17/XX	100	£956
S10-31000-18/XX	200	£1264

H 1000 mm 9 Drawers



27 28
100 S 100 T
100 S 100 T
100 S 100 T
100 S 100 T
100 S 100 T
100 S 100 T
100 S 100 T
100 S 100 T
100 S 100 T
100 S 100 T

Art. Nr.	KG	Price
S10-31000-27/XX	100	£970
S10-31000-28/XX	200	£1278

H 1000 mm 10 Drawers



32
75 T
75 T
75 T
75 T
100 T
100 T
100 T
100 T
100 T
100 T
100 T

Art. Nr.	KG	Price
S10-31000-32/XX	200	£1348

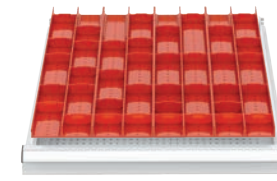

TROUGHS

For front height	Part. No.	Price
50 mm and higher	S07-30002	£55
16 Troughs 2 grooves Ø 70 mm		
38 Trough dividers		

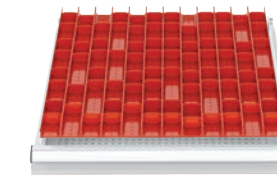

TROUGHS

For front height	Part. No.	Price
50 mm and higher	S07-30003	£62
16 Troughs 3 grooves Ø 45 mm		
51 Trough dividers		

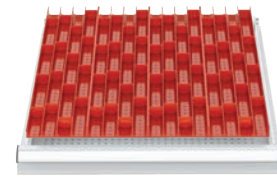

TROUGHS

For front height	Part. No.	Price
50 mm and higher	S07-30004	£68
16 Troughs 4 grooves Ø 33 mm		
64 Trough dividers		

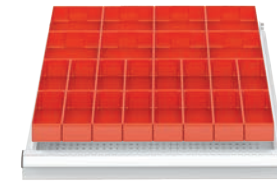

PLASTIC BOXES

For front height	Part. No.	Price
75 mm	S07-31407	£57
100-125 mm	S07-31410	£72
16 Plastic boxes 150x75 mm		
8 Plastic boxes 150x150 mm		

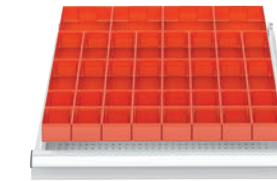

PLASTIC BOXES

For front height	Part. No.	Price
75 mm	S07-31507	£68
16 Plastic boxes 75x75 mm		
16 Plastic boxes 150x75 mm		
4 Plastic boxes 150x150 mm		



ANTI-SLIP PERFORATED MAT

Kit	Part. No.	Price
4 pcs.	S04-30844-04	£76
Dimensions: 600x600x3 mm h		
Colour: Black		

COLOUR
When ordering, please complete the article number by adding the desired two-digit colour code.

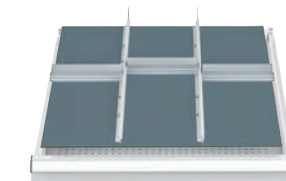
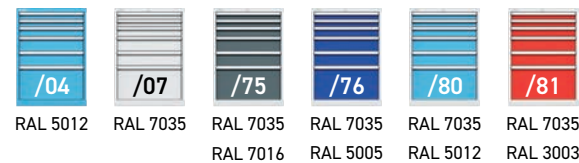

SLOTTED PARTITIONS

For front height	Part. No.	Price
75 mm	S07-33107	£26
100-125 mm	S07-33110	£30
150 mm	S07-33115	£33
200-250 mm	S07-33120	£38
2 Slotted partitions 36 Eh - 612 mm		
3 Aluminium dividers 12 Eh - 200 mm		

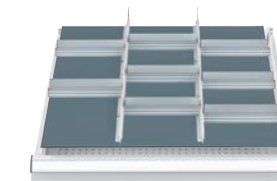

SLOTTED PARTITIONS

For front height	Part. No.	Price
75 mm	S07-33207	£31
100-125 mm	S07-33210	£37
150 mm	S07-33215	£45
200-250 mm	S07-33220	£57
2 Slotted partitions 36 Eh - 612 mm		
8 Aluminium dividers 12 Eh - 200 mm		

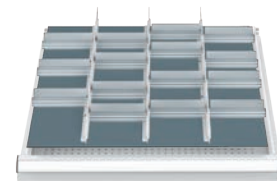

SLOTTED PARTITIONS

For front height	Part. No.	Price
75 mm	S07-33307	£41
100-125 mm	S07-33310	£52
150 mm	S07-33315	£62
200-250 mm	S07-33320	£72
3 Slotted partitions 36 Eh - 612 mm		
15 Aluminium dividers 9 Eh - 149 mm		

DRAWER CABINETS

870x572 mm - 45x27 Eh

H 850 mm 7 Drawers



16
75 T
75 T
100 T
100 T
125 T
125 T
150 T

Art. Nr. 200 **£1061**

S11-40850-16/XX

H 1000 mm 10 Drawers

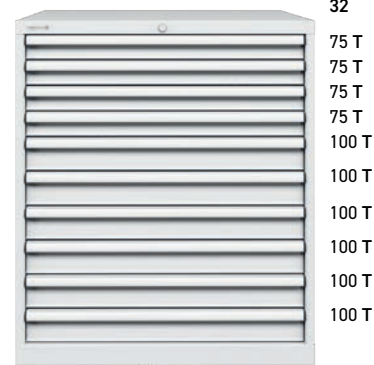

32
75 T
75 T
75 T
75 T
100 T
100 T
100 T
100 T
100 T
100 T

Art. Nr. 200 **£1348**

S11-41000-32/XX

H 1064 mm 7 Drawers



16
75 T
75 T
100 T
100 T
125 T
125 T
150 T

Art. Nr. 100 **£1334**

S11-49870C-16/XX



DRAWER CABINETS

870x725 mm - 45x36 Eh

H 1000 mm 7 Drawers

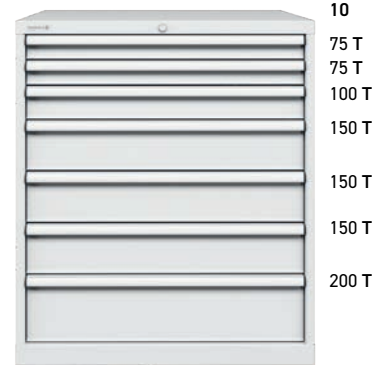

10
75 T
75 T
100 T
150 T
150 T
150 T
200 T

Art. Nr. 200 **£1152**

S10-41000-10/XX

H 1000 mm 8 Drawers

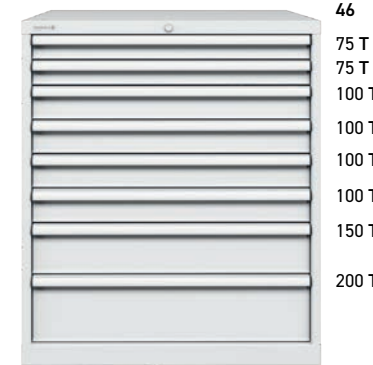

46
75 T
75 T
100 T
100 T
100 T
100 T
150 T
200 T

Art. Nr. 200 **£1236**

S10-41000-46/XX

H 1000 mm 9 Drawers

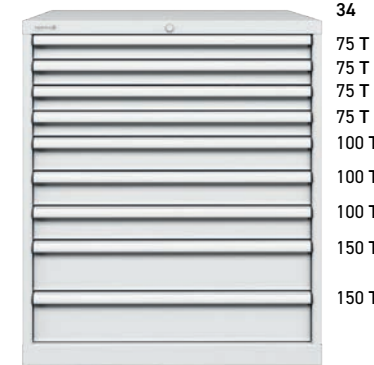

34
75 T
75 T
75 T
75 T
100 T
100 T
100 T
150 T
150 T

Art. Nr. 200 **£1320**

S10-41000-34/XX

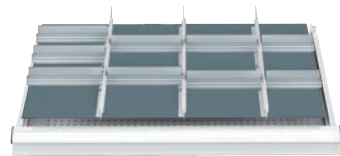

SLOTTED PARTITIONS

For front height	Part. No.	
75 mm	S08-43307	£37
100-125 mm	S08-43310	£43
150 mm	S08-43315	£52
200-250 mm	S08-43320	£65

3 Slotted partitions 27 Eh - 459 mm
2 Aluminium dividers 9 Eh - 149 mm
7 Aluminium dividers 12 Eh - 200 mm

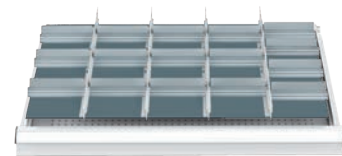

SLOTTED PARTITIONS

For front height	Part. No.	
75 mm	S08-43407	£47
100-125 mm	S08-43410	£57
150 mm	S08-43415	£68
200-250 mm	S08-43420	£82

4 Slotted partitions 27 Eh - 459 mm
16 Aluminium dividers 9 Eh - 149 mm



ANTI-SLIP PERFORATED MAT

	Part. No.	
Kit 4 pcs.	S04-30855-04	£99

Dimensions: 750x450x3 mm h
Colour: Black

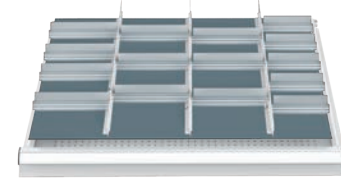

SLOTTED PARTITIONS

For front height	Part. No.	
75 mm	S07-43307	£43
100-125 mm	S07-43110	£52
150 mm	S07-43115	£65
200-250 mm	S07-43120	£85

3 Slotted partitions 36 Eh - 612 mm
5 Aluminium dividers 9 Eh - 149 mm
10 Aluminium dividers 12 Eh - 200 mm

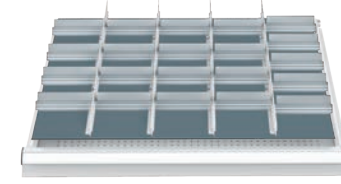

SLOTTED PARTITIONS

For front height	Part. No.	
75 mm	S07-43407	£52
100-125 mm	S07-43410	£67
150 mm	S07-43415	£79
200-250 mm	S07-43420	£96

4 Slotted partitions 36 Eh - 612 mm
21 Aluminium dividers 9 Eh - 149 mm



ANTI-SLIP PERFORATED MAT

	Part. No.	
Kit 4 pcs.	S04-30854-04	£102

Dimensions: 750x600x3 mm h
Colour: Black

COLOUR

When ordering, please complete the article number by adding the desired two-digit colour code.

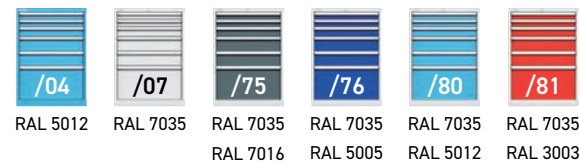

DRAWER CABINETS

1023x572 mm - 54x27 Eh

H 850 mm 6 Drawers

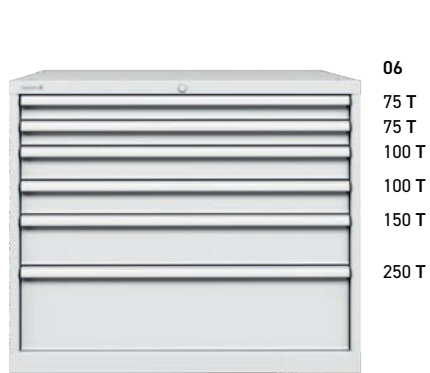

Art. Nr.  **£1026**
S11-50850-06/XX 200

H 1000 mm 7 Drawers

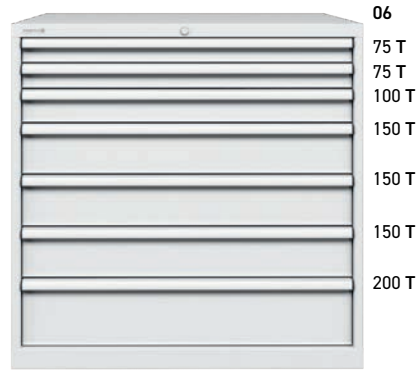

Art. Nr.  **£1124**
S11-51000-06/XX 200

H 850 mm 8 Drawers

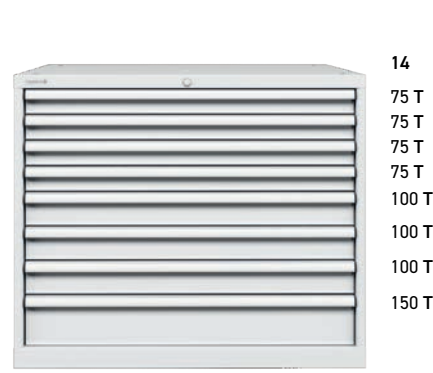

Art. Nr.  **£1194**
S11-50850-14/XX 200

H 1000 mm 9 Drawers

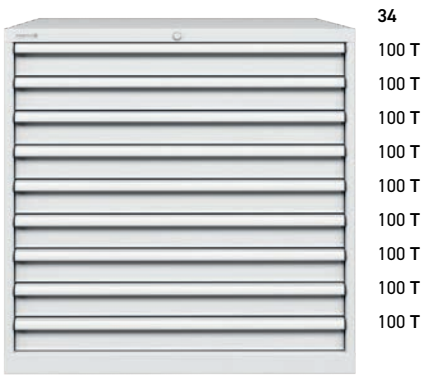

Art. Nr.  **£1306**
S11-51000-34/XX 200

H 1000 mm 10 Drawers

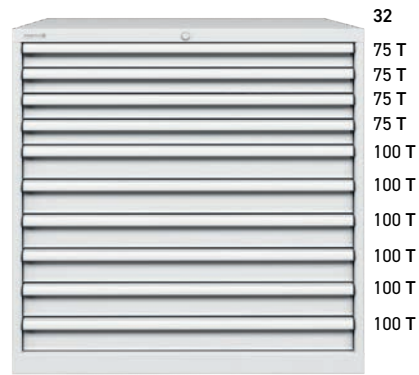

Art. Nr.  **£1390**
S11-51000-32/XX 200

DRAWER CABINETS

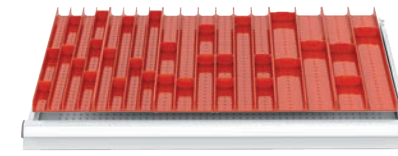

TROUGHS

For front height	Part. No.	
50 mm and higher	S08-50234	£58
6 Troughs 2 grooves \varnothing 70 mm		
6 Troughs dividers		
6 Troughs 3 grooves \varnothing 45 mm		
10 Troughs dividers		
6 Troughs 4 grooves \varnothing 33 mm		
15 Trough dividers		



PLASTIC BOXES

For front height	Part. No.	
75 mm	S08-51407	£60
100-125 mm	S08-51410	£75
12 Plastic boxes 150x75 mm		
12 Plastic boxes 150x150 mm		

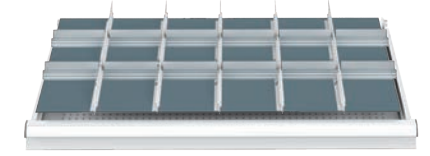

SLOTTED PARTITIONS

For front height	Part. No.	
75 mm	S08-53507	£48
100-125 mm	S08-53510	£57
150 mm	S08-53515	£67
200-250 mm	S08-53520	£79
5 Slotted partitions 27 Eh - 459 mm		
12 Aluminium dividers 9 Eh - 149 mm		



ANTI-SLIP PERFORATED MAT

	Part. No.	
Kit 4 pcs.	S04-30864-04	£107
Dimensions: 900x450x3 mm h		
Colour: Black		

COLOUR

When ordering, please complete the article number by adding the desired two-digit colour code.

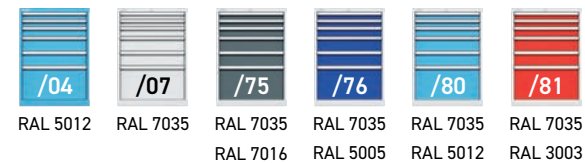

DRAWER CABINETS

1023x725 mm - 54x36 Eh

H 850 mm 6 Drawers

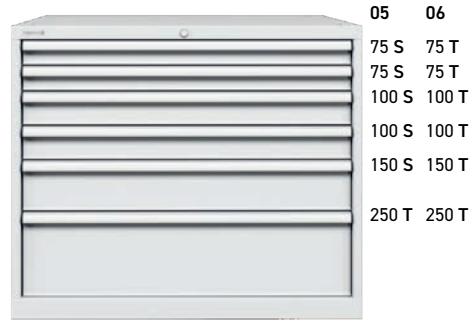

Art. Nr.	KG	Price
S10-50850-05/XX	100	£942
S10-50850-06/XX	200	£1138

H 850 mm 6 Drawers



Art. Nr.	KG	Price
S10-50850-13/XX	200	£1152

H 1000 mm 7 Drawers

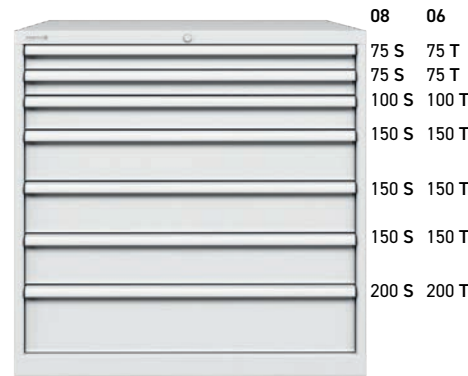

Art. Nr.	KG	Price
S10-51000-08/XX	100	£1012
S10-51000-06/XX	200	£1264

H 1000 mm 10 Drawers

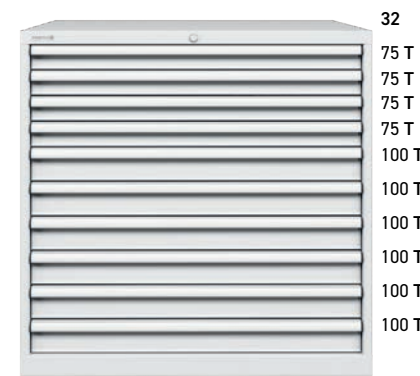

Art. Nr.	KG	Price
S10-51000-32/XX	200	£1559

H 1064 mm 7 Drawers



Art. Nr.	KG	Price
S10-59870C-10/XX	200	£1376

H 1000 mm 8 Drawers

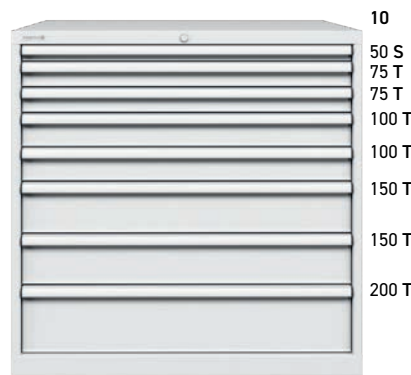

Art. Nr.	KG	Price
S10-51000-10/XX	200	£1334

H 1000 mm 8 Drawers

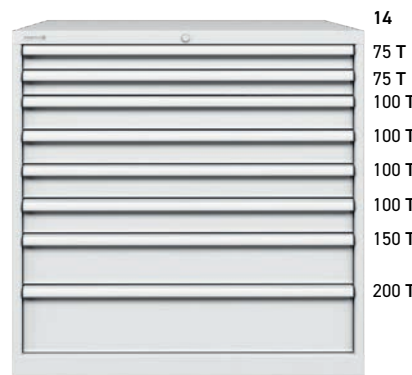

Art. Nr.	KG	Price
S10-51000-14/XX	200	£1362

H 1000 mm 9 Drawers

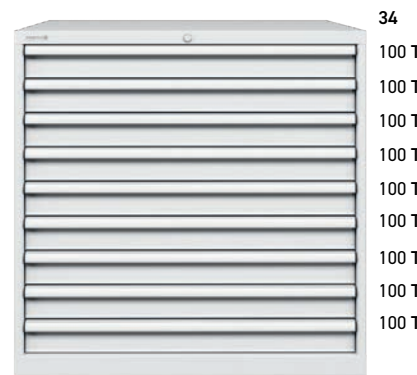

Art. Nr.	KG	Price
S10-51000-34/XX	200	£1460

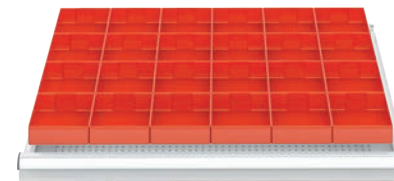

PLASTIC BOXES

For front height	Part. No.	Price
50 mm	S07-51205	£67
75 mm	S07-51207	£71
100-125 mm	S07-51210	£82

24 Plastic boxes 150x150 mm

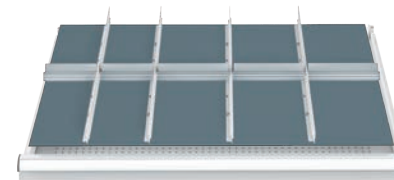

SLOTTED PARTITIONS

For front height	Part. No.	Price
50 mm	S07-53405	£34
75 mm	S07-53407	£37
100-125 mm	S07-53410	£43
150 mm	S07-53415	£50
200-250 mm	S07-53420	£61

4 Slotted partitions 36 Eh - 612 mm
2 Aluminium dividers 9 Eh - 149 mm
3 Aluminium dividers 12 Eh - 200 mm

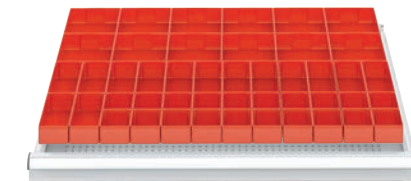

PLASTIC BOXES

For front height	Part. No.	Price
50 mm	S07-51505	£83
75 mm	S07-51507	£89

20 Plastic boxes 75x75 mm
14 Plastic boxes 150x75 mm
12 Plastic boxes 150x150 mm

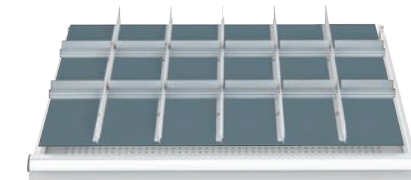

SLOTTED PARTITIONS

For front height	Part. No.	Price
50 mm	S07-53505	£45
75 mm	S07-53507	£50
100-125 mm	S07-53510	£58
150 mm	S07-53515	£68
200-250 mm	S07-53520	£82

5 Slotted partitions 36 Eh - 612 mm
12 Aluminium dividers 9 Eh - 149 mm

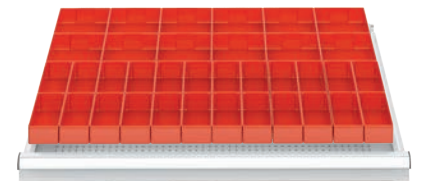

PLASTIC BOXES

For front height	Part. No.	Price
50 mm	S07-51605	£72
75 mm	S07-51607	£79
100-125 mm	S07-51610	£103

24 Plastic boxes 150x75 mm
12 Plastic boxes 150x150 mm



ANTI-SLIP PERFORATED MAT

Part. No.		Price
Kit 4 pcs.	S04-30874-04	£117

Dimensions: 900x600x3 mm
Colour: Black

COLOUR

When ordering, please complete the article number by adding the desired two-digit colour code.

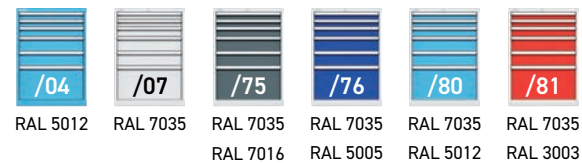

COMBO WORKBENCHES

L 1500 mm

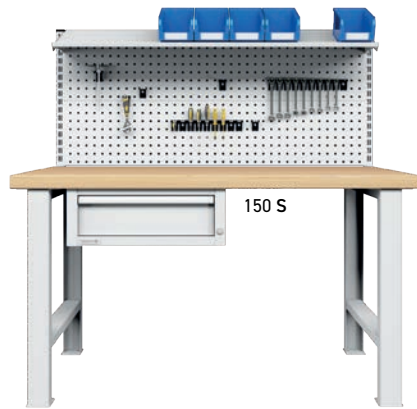

Part. No.	Worktop	KG	
S144-80157-003/XX	Multiplex	800	£878
S144-80157-603/XX	Rubber mat cover	800	£1019

Worktop 1500x750x40 mm h
Cabinet 233 mm h with 1 Drawer
Perforated back panel 631 mm h with 2 panels and 1 shelf
Workbench total height 840 mm
with 5 plastic BINS size 2

L 1500 mm

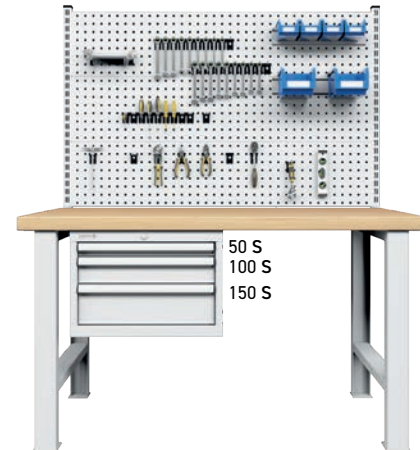

Part. No.	Worktop	KG	
S144-80157-005/XX	Multiplex	800	£1124
S144-80157-605/XX	Rubber mat cover	800	£1264

Worktop 1500x750x40 mm h
Cabinet 383 mm h with 3 Drawers
Perforated back panel 935 mm h with 3 panels
Workbench total height 840 mm
with 15 HOOK KIT

L 2000 mm

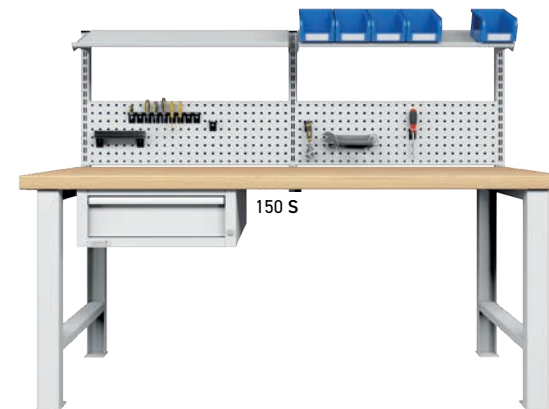

Part. No.	Worktop	KG	
S144-80207-003/XX	Multiplex	800	£1005
S144-80207-603/XX	Rubber mat cover	800	£1173

Worktop 2000x750x40 mm h
Cabinet 233 mm h with 1 Drawer
Perforated back panel 631 mm h with 2 panels and 2 shelves
Workbench total height 840 mm
with 5 plastic BINS size 2

L 2000 mm

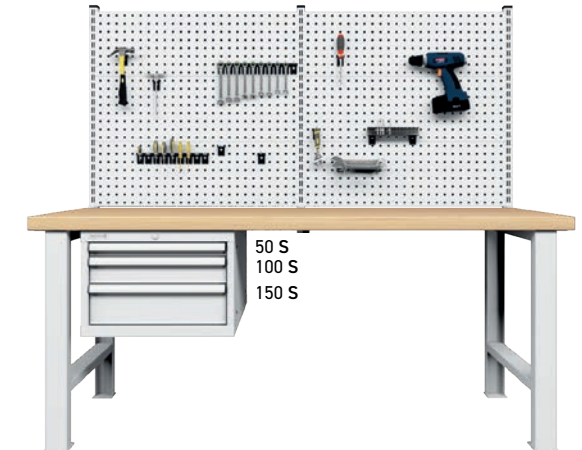

Part. No.	Worktop	KG	
S144-80207-005/XX	Multiplex	800	£1299
S144-80207-605/XX	Rubber mat cover	800	£1468

Worktop 2000x750x40 mm h
Cabinet 383 mm h with 3 Drawers
Perforated back panel 935 mm h with 6 panels
Workbench total height 840 mm
with 15 HOOK KIT

L 1500 mm

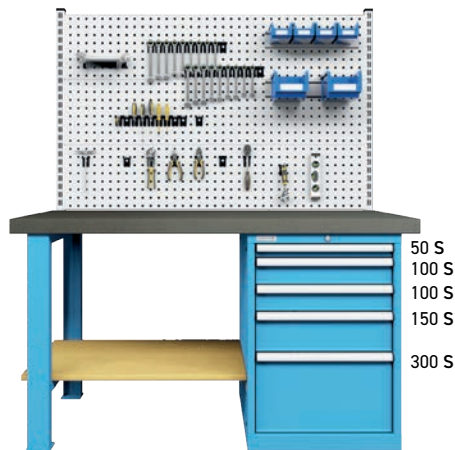

Part. No.	Worktop	KG	
S144-80157-019/XX	Multiplex	800	£1334
S144-80157-619/XX	Rubber mat cover	800	£1475

Worktop 1500x750x40 mm h
Cabinet 800 mm h with 5 Drawers
Perforated back panel 631 mm h with 3 panels
1 Wood shelf
Workbench total height 840 mm
with 20 HOOK KIT

£75

S06-97015 Hooks for perforated panels - 15 pcs.



£110

S06-97020 Hooks for perforated panels - 20 pcs.

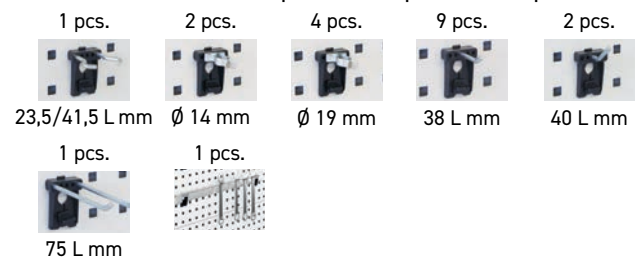

L 2000 mm



Part. No.	Worktop	KG	
S144-80207-019/XX	Multiplex	800	£1517
S144-80207-619/XX	Rubber mat cover	800	£1685

Worktop 2000x750x40 mm h
Cabinet 800 mm h with 5 Drawers
Perforated back panel 935 mm h with 6 panels
1 Wood shelf
Workbench total height 840 mm
with 20 HOOK KIT

COLOUR

When ordering, please complete the article number by adding the desired two-digit colour code.

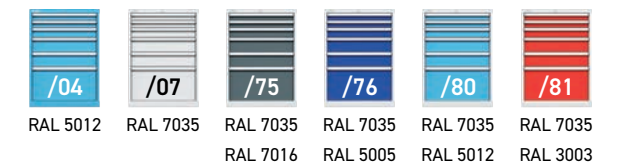

COMBO WORKBENCHES

L 1500 mm



Part. No.	Worktop	KG	Price
S11-80156-012/XX	Rubber mat cover	1200	£2288

Worktop 1500x600x40 mm h
 1 Cabinet 36x27 Eh 1000 mm h with 6 Drawers
 1 Cabinet 36x27 Eh 1000 mm h with 7 Drawers
 WITHOUT PARTITIONING MATERIAL

LOAD CAPACITY (DRAWER)
 200 Kg.

L 2050 mm



Part. No.	Worktop	KG	Price
S11-PBA850-01/XX	Rubber mat cover	1200	£2316

Worktop 2050x600x30 mm
 1 Cabinet 54x27 Eh 850 mm h with 8 Drawers
 1 Cabinet 54x27 Eh 850 mm h with hinged doors and 1 Adjustable shelf
 2 Base plinths 100 m h
 WITHOUT PARTITIONING MATERIAL

LOAD CAPACITY (DRAWER)
 200 Kg.

COLOUR

When ordering, please complete the article number by adding the desired two-digit colour code.

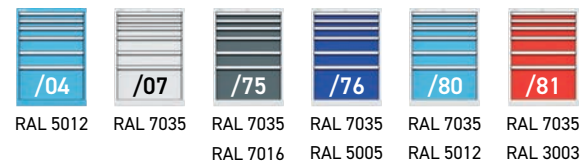

PERFORATED BACK PANELS

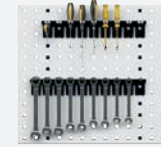

Part. No.	Price
S06-45050/XX without hooks 500x456x22 mm	£82

WITHOUT SUPPORTS FOR FIXING

Part. No.	Price
S06-45100/XX without hooks 1000x456x22 mm	£96

WITHOUT SUPPORTS FOR FIXING

Part. No.	Price
S06-45150/XX without hooks 1500x456x22 mm	£155

WITHOUT SUPPORTS FOR FIXING

COLOUR

When ordering, please complete the article number by adding the desired two-digit colour code (e. g. S06-45050/04)



HOOKS

pg. 52



AUTOMOTIVE



WORKBENCHES

L 1500 mm



Part. No.	Worktop	KG	Price
S44-80157-001/XX	Multiplex	800	£437
S44-80157-601/XX	Rubber mat cover	800	£577

L 1500 mm

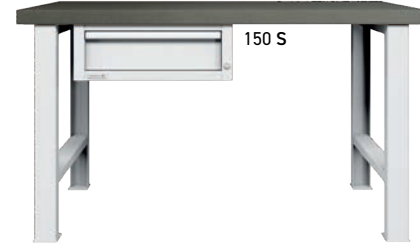

Part. No.	Worktop	KG	Price
S44-80157-003/XX	Multiplex	800	£626
S44-80157-603/XX	Rubber mat cover	800	£766

L 1500 mm

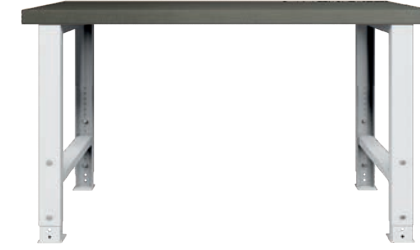

Part. No.	Worktop	KG	Price
S44-80157-022/XX	Multiplex	800	£493
S44-80157-622/XX	Rubber mat cover	800	£633

Adjustable height workbench from 790 to 1090 mm

H 631 mm

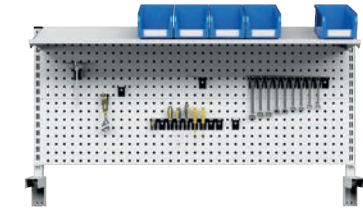

Part. No.	Length mm	Price
S49-15204/07	1500	£352

2 Perforated back panels and 1 shelf

L 1500 mm

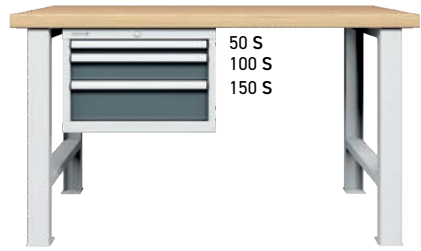

Part. No.	Worktop	KG	Price
S44-80157-005/XX	Multiplex	800	£822
S44-80157-605/XX	Rubber mat cover	800	£963

L 1500 mm



Part. No.	Worktop	KG	Price
S44-80157-007/XX	Multiplex	1400	£928
S44-80157-607/XX	Rubber mat cover	1400	£1068

L 1500 mm



Part. No.	Worktop	KG	Price
S44-80157-008/XX	Multiplex	1400	£977
S44-80157-608/XX	Rubber mat cover	1400	£1117

L 1500 mm



Part. No.	Worktop	KG	Price
S44-80157-019/XX	Multiplex	1400	£998
S44-80157-619/XX	Rubber mat cover	1400	£1138

S06-97015 HOOK KIT - 15 pcs. £75



S06-97020 HOOK KIT - 20 pcs. £110

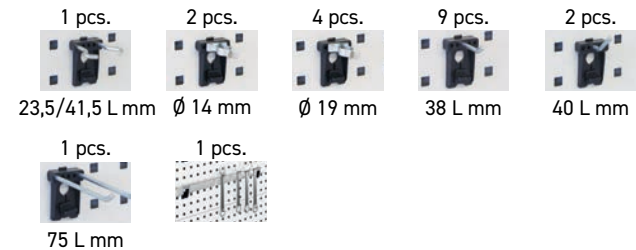

S06-97046 HOOK KIT - 46 pcs. £208

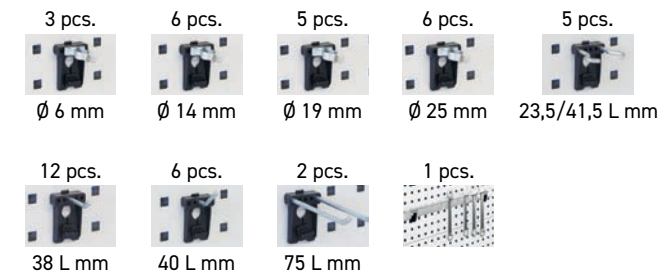

H 935 mm

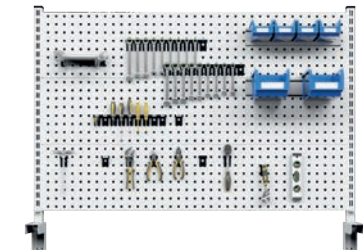

Part. No.	Length mm	Price
S49-15301/07	1500	£338

3 Perforated back panels

H 935 mm



Part. No.	Length mm	Socket block	Price
S49-15166/07	1500	GB-240 V	£808

1 Perforated back panel, 1 shelf, 1 overhead light LED, 1 Socket block with 4 sockets and 1 switch ON/OFF

COLOUR

When ordering, please complete the article number by adding the desired two-digit colour code.

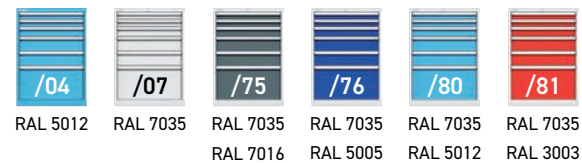

Multiplex wood

Steam impregnated and veneered worktop with rounded corners and smooth surface.

Multiplex wood with rubber mat cover

Veneered Multiplex worktop with 1.2 mm thick steel cover with oil-resistant rubber

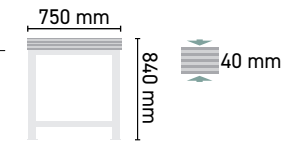

WORKBENCHES

L 2000 mm



Part. No.	Worktop	KG	
S44-80207-001/XX	Multiplex	400	£507
S44-80207-601/XX	Rubber mat cover	400	£675

L 2000 mm



Part. No.	Worktop	KG	
S44-80207-003/XX	Multiplex	400	£703
S44-80207-603/XX	Rubber mat cover	400	£871

L 2000 mm



Part. No.	Worktop	KG	
S44-80207-019/XX	Multiplex	800	£1068
S44-80207-619/XX	Rubber mat cover	800	£1236

L 2000 mm



Part. No.	Worktop	KG	
S44-80207-022/XX	Multiplex	400	£556
S44-80207-622/XX	Rubber mat cover	400	£724

Adjustable height workbench from 790 to 1090 mm

L 2000 mm

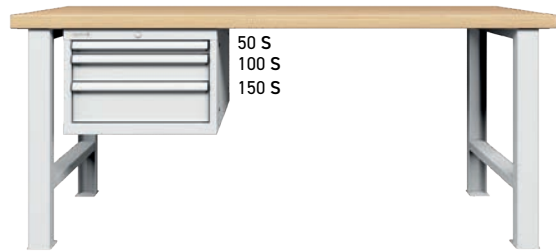

Part. No.	Worktop	KG	
S44-80207-005/XX	Multiplex	400	£885
S44-80207-605/XX	Rubber mat cover	400	£1054

L 2000 mm



Part. No.	Worktop	KG	
S44-80207-007/XX	Multiplex	800	£984
S44-80207-607/XX	Rubber mat cover	800	£1152

H 631 mm

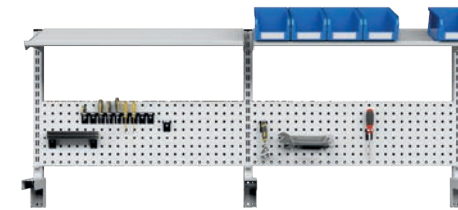

Part. No.	Length mm	
S49-20203/07	2000	£402

2 Perforated back panels and 2 shelves

H 935 mm

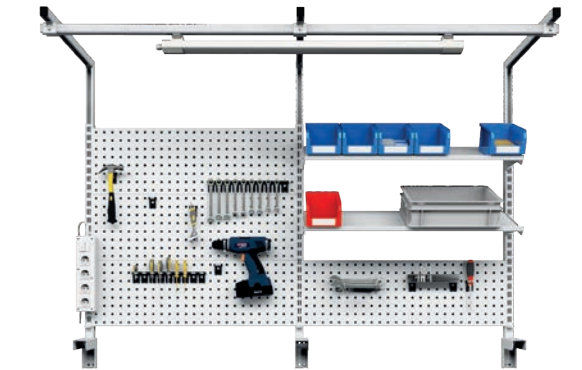

Part. No.	Length mm	Socket block	
S49-20466/07	2000	GB-240 V	£984

4 Perforated back panels, 2 shelves, 1 overhead light LED, 1 Socket block with 4 sockets and 1 switch ON/OFF

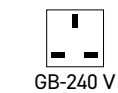

L 2000 mm



Part. No.	Worktop	KG	
S44-80207-008/XX	Multiplex	800	£1040
S44-80207-608/XX	Rubber mat cover	800	£1208

L 2000 mm



Part. No.	Worktop	KG	
S44-80207-012/XX	Multiplex	1000	£1496
S44-80207-612/XX	Rubber mat cover	1000	£1664

H 935 mm

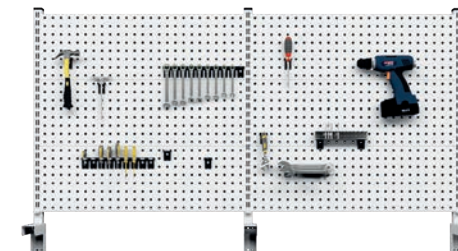

Part. No.	Length mm	
S49-20301/07	2000	£451

6 Perforated back panels

HOOKS
pg. 52



COLOUR

When ordering, please complete the article number by adding the desired two-digit colour code.

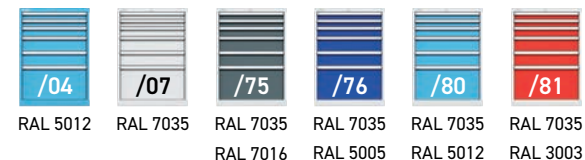

Multiplex wood
Steam impregnated and veneered worktop with rounded corners and smooth surface.

Multiplex wood with rubber mat cover
Veneered Multiplex worktop with 1.2 mm thick steel cover with oil-resistant rubber

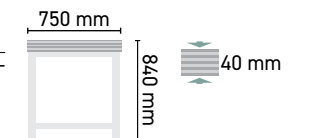

MOBILE WORKBENCHES

L 1000 mm



Part. No.	Worktop	KG	
S43-80107-051/XX	Multiplex	400	£528
S43-80107-651/XX	Rubber mat cover	400	£668

L 1000 mm



Part. No.	Worktop	KG	
S43-80107-052/XX	Multiplex	400	£731
S43-80107-652/XX	Rubber mat cover	400	£871

L 1500 mm

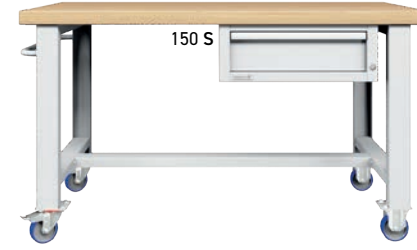

Part. No.	Worktop	KG	
S43-80157-052/XX	Multiplex	400	£787
S43-80157-652/XX	Rubber mat cover	400	£928

L 2000 mm



Part. No.	Worktop	KG	
S43-80207-052/XX	Multiplex	400	£843
S43-80207-652/XX	Rubber mat cover	400	£1012

L 1500 mm



Part. No.	Worktop	KG	
S43-80157-051/XX	Multiplex	400	£577
S43-80157-651/XX	Rubber mat cover	400	£717

L 2000 mm



Part. No.	Worktop	KG	
S43-80207-051/XX	Multiplex	400	£640
S43-80207-651/XX	Rubber mat cover	400	£808

L 1500 mm

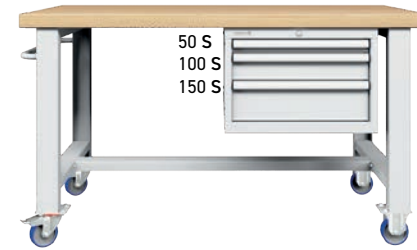

Part. No.	Worktop	KG	
S43-80157-053/XX	Multiplex	400	£928
S43-80157-653/XX	Rubber mat cover	400	£1068

L 2000 mm

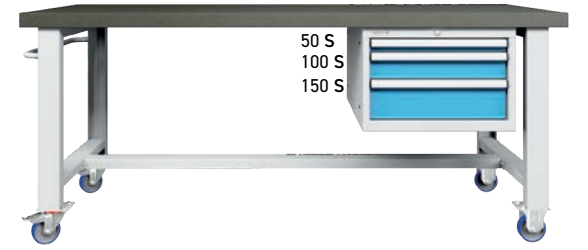

Part. No.	Worktop	KG	
S43-80207-053/XX	Multiplex	400	£998
S43-80207-653/XX	Rubber mat cover	400	£1166

COLOUR

When ordering, please complete the article number by adding the desired two-digit colour code.

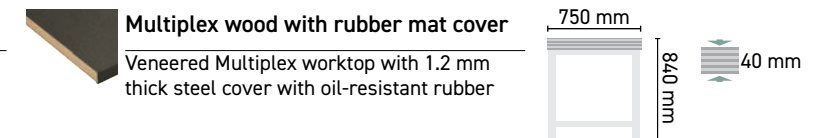
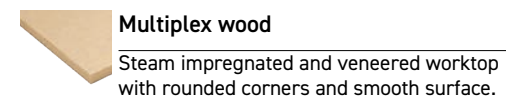
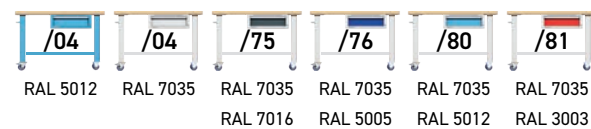

COMPACT WORKBENCHES

L 1500 mm



Part. No.	Worktop	KG	
S42-84157-001/XX	Multiplex	800	£1026
S42-84157-601/XX	Rubber mat cover	800	£1166

L 1500 mm



Part. No.	Worktop	KG	
S42-84157-003/XX	Multiplex	800	£1040
S42-84157-603/XX	Rubber mat cover	800	£1180

Part. No.	Length mm	
S42-15204/07	1136	£275

2 Perforated back panels

L 1500 mm

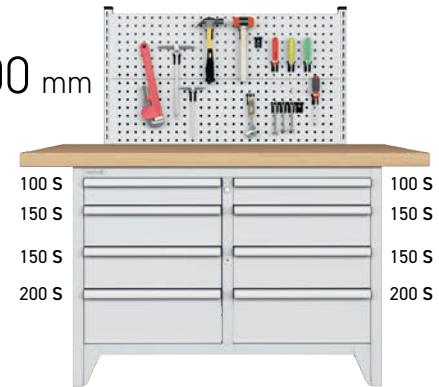

Part. No.	Worktop	KG	
S42-84157-006/XX	Multiplex	800	£1278
S42-84157-606/XX	Rubber mat cover	800	£1418

L 1500 mm



Part. No.	Worktop	KG	
S42-84157-007/XX	Multiplex	800	£1151
S42-84157-607/XX	Rubber mat cover	800	£1292

MOBILE COMPACT WORKBENCHES

L 1065 mm

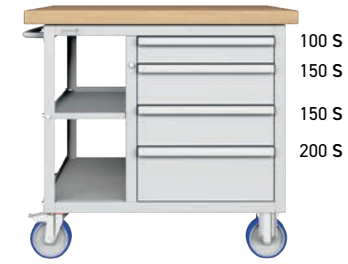

Part. No.	Worktop	KG	
S47-90020-002/XX	Multiplex	400	£1138
S47-90020-602/XX	Rubber mat cover	400	£1278

L 1065 mm



Part. No.	Worktop	KG	
S47-91020-006/XX	Multiplex	400	£1208
S47-91020-606/XX	Rubber mat cover	400	£1348

L 1315 mm



Part. No.	Worktop	KG	
S47-91120-006/XX	Multiplex	400	£1236
S47-91120-606/XX	Rubber mat cover	400	£1376

L 1315 mm



Part. No.	Worktop	KG	
S47-91120-008/XX	Multiplex	400	£1600
S47-91120-608/XX	Rubber mat cover	400	£1740

COLOUR

When ordering, please complete the article number by adding the desired two-digit colour code.

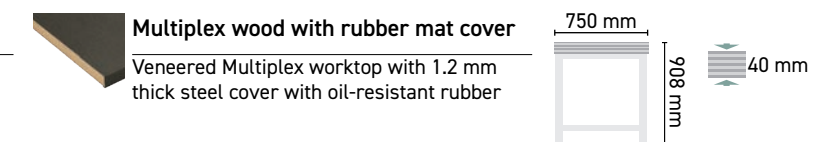
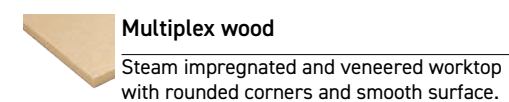

HEIGHT ADJUSTABLE BENCH - ELECTRONIC OPERATION

There are several benefits to a sit stand workbench – the ability to switch to standing and sitting postures reduces physical stress, keeps you active and improves productivity. Gone are the days where you complain about worksurface heights just not being quite right. With a press of a button you can instantly personalise the working surface height to your optimum needs.

Due to electronically powered motorised bench legs the adjustment varies from a height of 750 mm up to a maximum of 1050 mm. The smooth and controlled movement makes the adjustment effortless.

The maximum load capacity of our electronic workbenches is 400 kg, giving you the flexibility to customise the bench design with additional features including drawer cabinets, power bars, perforated panels, shelves, overhead rails and lighting options.

With a premium hard wearing laminate, 40 mm worktop core and anodised aluminium support legs this makes our Series E48 workbench perfectly suited to workshop, warehouse and light industrial environments.

STANDARD COLOUR

07 RAL 7035

LIFTING COLUMNS

Aluminium

LOAD CAPACITY: 400 Kg

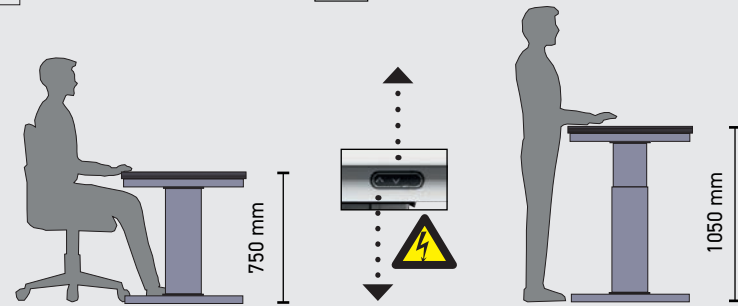

L 1500 mm

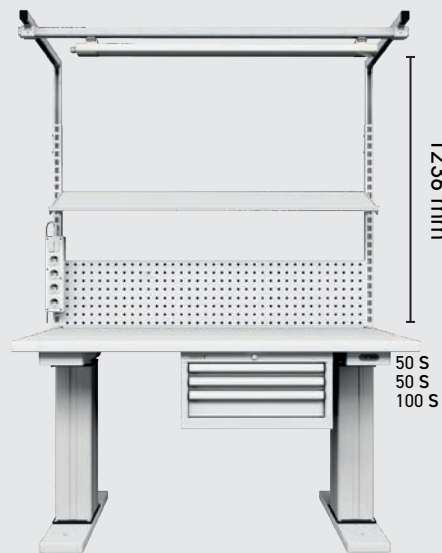

Part. No.	Worktop	KG	
E148-84157-065/07	Multiplex	400	POA
E148-84157-265/07	Plastic laminated	400	POA

1500x750x750/1050 mm h

1 Cabinet 383 mm h with 3 Drawers

1 Perforated back panel

1 Shelf

1 Socket block with 4 sockets UK and 1 overhead light LED

European electrical system



GB-240 V
S148-84157-X65

L 2000 mm



Part. No.	Worktop	KG	
E148-84207-065/07	Multiplex	400	POA
E148-84207-265/07	Plastic laminated	400	POA

2000x750x750/1050 mm h

1 Cabinet 383 mm h with 3 Drawers

4 Perforated back panels

2 Shelves

1 Socket block with 4 sockets UK and 1 overhead light LED

European electrical system



GB-240 V
S148-84207-X65

CANTILEVER WORKBENCHES

L 1500 mm

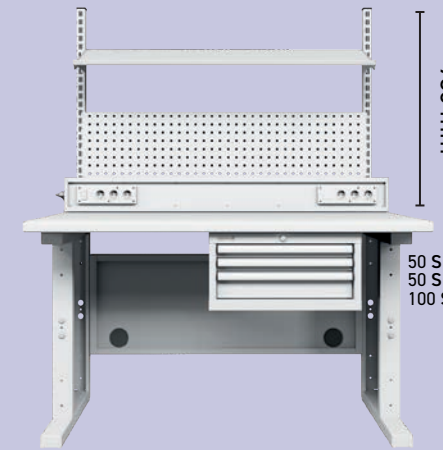

Part. No.	Worktop	KG	
S48-84157-067/07	Multiplex	400	£1727
S48-84157-267/07	Plastic laminated	400	£2049

1500x750x840 mm h

1 Cabinet 383 mm h with 3 Drawers

1 Perforated back panel

1 Shelf

1 Socket block with 6 sockets UK and 1 Switch ON/OFF



GB-240 V
S48-84157-X67

L 2000 mm



Part. No.	Worktop	KG	
S48-84207-067/07	Multiplex	400	£2022
S48-84207-267/07	Plastic laminated	400	£2302

2000x750x840 mm h

1 Cabinet 383 mm h with 3 Drawers

1 Perforated back panel

2 Shelves

1 Socket block with 6 sockets UK and 1 Switch ON/OFF



GB-240 V
S48-84207-X67



ANTI-FATIGUE MATTING

Anti-fatigue floor mats help reduce fatigue and increase productivity making them ideal for the workplace. Whilst giving extra comfort for prolonged standing they improve health and safety with a yellow safety border.

The underside structure design allows for cable management. Easy to assemble with clip connectors.

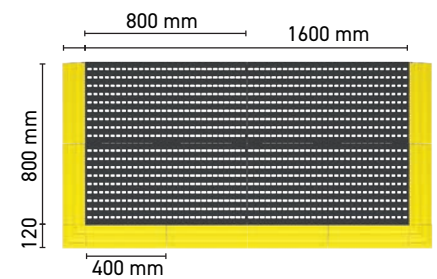
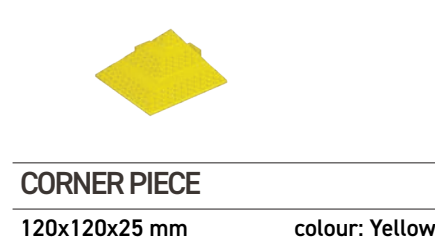
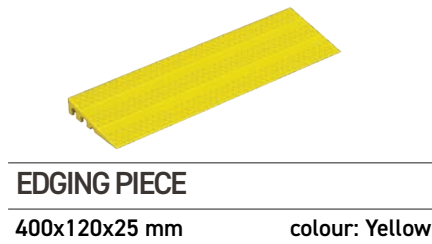
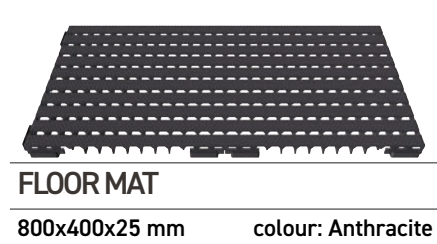

Part. No.	Price
S98-80208-001	£145
1840x920 mm	
4 Floor mats	
8 Edging pieces	
2 Corner pieces	

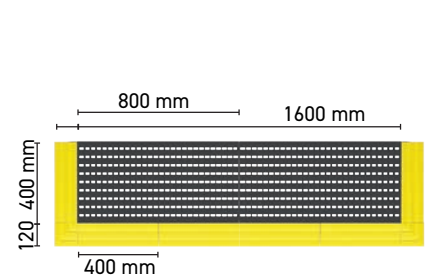

Part. No.	Price
S98-80208-002	£89
1840x520 mm	
2 Floor mats	
6 Edging pieces	
2 Corner pieces	

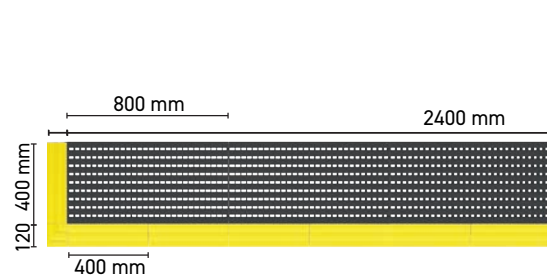

Part. No.	Price
S98-80208-009	£117
2640x520 mm	
3 Floor mats	
8 Edging pieces	
2 Corner pieces	

ROLLER SHUTTER CABINETS

Fixed to the worktop



Part. No.	H	Price
S40-91008/XX	810 mm	£479
S40-91010/XX	1114 mm	£535
952x210xH mm		

Fixed to the worktop

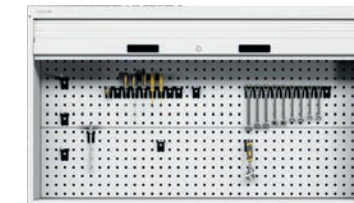

Part. No.	H	Price
S40-94008/XX	810 mm	£647
S40-94010/XX	1114 mm	£745
1419x210xH mm		

Fixed to the worktop

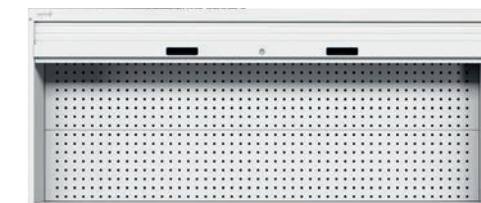

Part. No.	H	Price
S40-96008/XX	810 mm	£1110
S40-96010/XX	1114 mm	£1264
1419x210xH mm		

COLOUR

When ordering, please complete the article number by adding the desired two-digit colour code (e. g. S40-96008/04)



Fixed to the wall



Part. No.	H	Price
S40-91208/XX	810 mm	£577
S40-91210/XX	1114 mm	£633
952x210xH mm		

Fixed to the wall

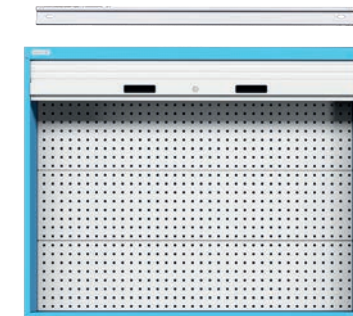

Part. No.	H	Price
S40-94208/XX	810 mm	£801
S40-94210/XX	1114 mm	£885
1419x210xH mm		

Fixed to the wall

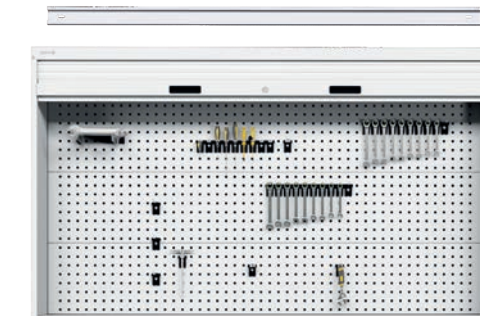

Part. No.	H	Price
S40-96208/XX	810 mm	£1292
S40-96210/XX	1114 mm	£1446
1419x210xH mm		

HOOKS

pg. 52



HOOKS FOR PERFORATED BACK PANELS

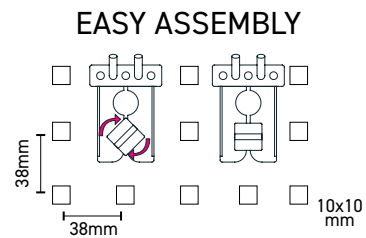

S06-97015 - 15 HOOK **£75**



Pcs.	Part. No.	Description
3	S06-71742	Hammer and plier holder - 41,5 mm L / \varnothing 27,5 mm
4	S06-71414	Spring clip - \varnothing 14 mm
5	S06-70040	Single hook - 38 mm L
1	S06-70100	Single hook - 100 mm L
2	S06-71419	Spring clip - \varnothing 19 mm

S06-97020 - 20 HOOK **£110**



Pcs.	Part. No.	Description
1	S06-71742	Hammer and plier holder - 41,5 mm L / \varnothing 27,5 mm
2	S06-71414	Spring clip - \varnothing 14 mm
1	S06-71075	Double hook - 75 mm L / Internal width 23,5 mm
9	S06-70040	Single hook - 38 mm L
2	S06-73035	Single angled hook - 40 mm L
4	S06-71419	Spring clip - \varnothing 19 mm
1	S06-77012	Spanner holder - 12 positions

S06-97046 - 46 HOOK **£208**

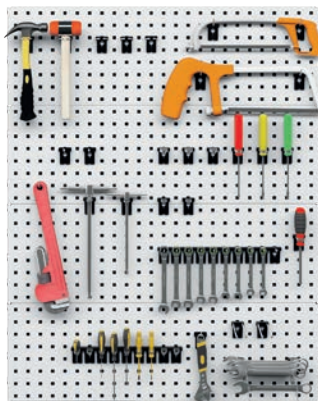

Pcs.	Part. No.	Description
3	S06-71706	Spring clip \varnothing 6 mm
5	S06-71742	Hammer and plier holder - 41,5 mm L / \varnothing 27,5 mm
6	S06-71414	Spring clip - \varnothing 14 mm
2	S06-71075	Double hook - 75 mm L / Internal width 23,5 mm
12	S06-70040	Single hook - 38 mm L
6	S06-73035	Single angled hook - 40 mm L
5	S06-71419	Spring clip - \varnothing 19 mm
6	S06-71425	Spring clip - \varnothing 25 mm
1	S06-77012	Spanner holder - 12 positions



HAMMER AND PLIER HOLDER

Part. No.	L	\varnothing	Price
S06-71728	45 mm	9,5/27,5 mm	£7
S06-71735	45 mm	16,5/34,5 mm	£7
S06-71742	45 mm	23,5/41,5 mm	£7

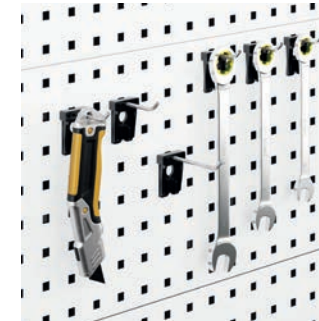

SINGLE HOOK

Part. No.	L	\varnothing	Price
S06-70040	38 mm	4,5 mm	£5
S06-70075	75 mm	4,5 mm	£6
S06-70100	100 mm	4,5 mm	£6

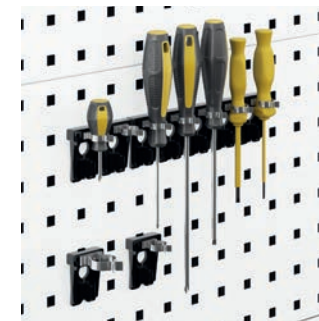

SPRING CLIP

Part. No.	\varnothing	Price
S06-71406	6 mm	£6
S06-71410	10 mm	£6
S06-71414	14 mm	£6
S06-71419	19 mm	£6
S06-71425	25 mm	£6



DOUBLE HOOK

Part. No.	L	Internal width	Price
S06-71055	38 mm	23,5 mm	£6
S06-71075	75 mm	23,5 mm	£6
S06-71100	100 mm	23,5 mm	£6
S06-71200	200 mm	23,5 mm	£6

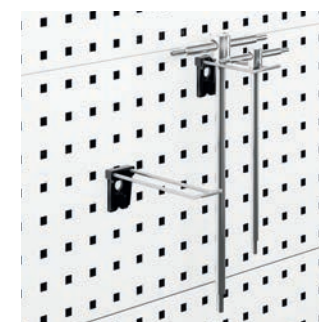

CLOSED DOUBLE HOOK

Part. No.	L	Internal width	Price
S06-72151	150 mm	28 mm	£7
S06-72200	200 mm	35 mm	£7

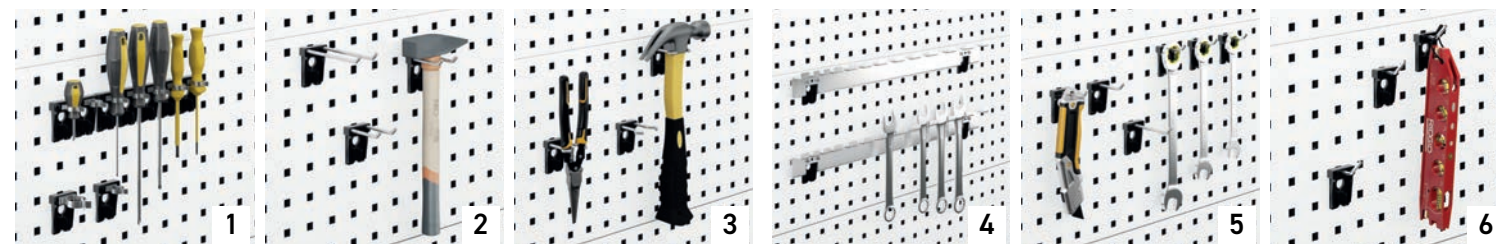

HOOKS FOR PERFORATED BACK PANELS



SINGLE ANGLED HOOK

Part. No.	L	∅	
S06-73035	35 mm	4,5 mm	£5

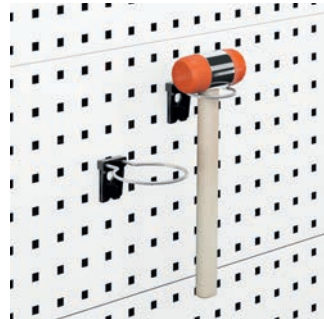

CLOSED HOOK

Part. No.	∅	
S06-74040	40 mm	£10
S06-74060	60 mm	£10



SCREW DRIVER HOLDER

Part. No.	L	∅	
S06-75032	240 mm	3-14 mm (32 holes)	£23

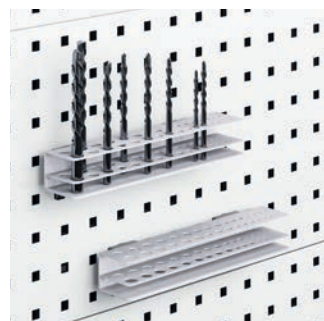

DRILL BIT HOLDER

Part. No.	L	∅	
S06-70032	240 mm	3-14 mm (32 holes)	£26



ROUND HOOK

Part. No.	∅	
S06-73060	60 mm	£7

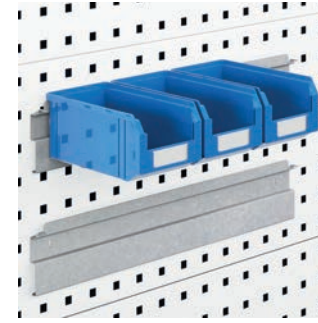

RAIL + PLASTIC BINS

Part. No.	Size	pcs.	
S106-00141	01	4	£31
S106-01041	1	4	£33
S106-02041	2	3	£40

Rail: 455x50x13 mm h



PLASTIC BINS

Part. No.	Size	Capacity	Kit Pcs.	
S70-001412	01 103x93x52 mm h	0,25 lt.	12	£31
S70-010412	1 103x169x75 mm h	1 lt.	12	£37
S70-020409	2 150x202x125 mm h	3,8 lt.	9	£48

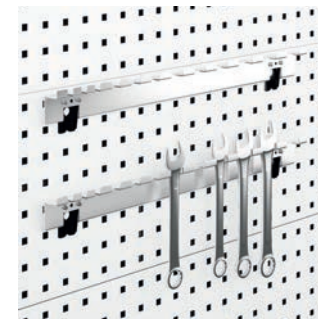

SPANNER HOLDER

Part. No.	L	Positions	
S06-77012	556 mm	12	£26



PLASTIC BOX

Part. No.	LxDxH	
S06-78001	95x95x34 mm	£5

COMPUTER CABINETS



Components:

- 1 - Built-in ventilator
- 2 - Dust filter
- 3 - 4 Sockets with 1 m connecting cable
- 4 - Retractable keyboard
- 5 - Mouse holder
- 6 - Central locking system to close upper and lower compartment - keyed alike

COLOUR

When ordering, please complete the article number by adding the desired two-digit colour code (e. g. S17-61626A-05/**04**)

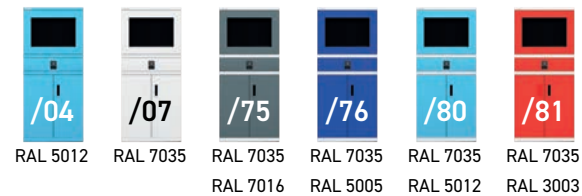

Part. No. SOCKET
S17-61626-00/XX GB-240 V **£1103**
717x595x1625 mm h

STANDARD

- Central locking system to close upper and lower compartment - keyed alike
- Monitor leaf door with Plexiglass® window for visibility
- Retractable keyboard drawer with mouse holder
- Built-in ventilator and dust filter to protect equipment from overheating
- 4 Sockets with 1 m connecting cable
- Lower compartment closed with hinged doors: 661x467x700 mm h

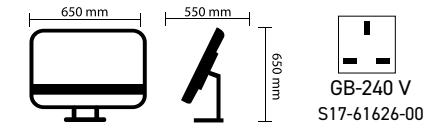

Part. No. SOCKET
S17-61626-01/XX GB-240 V **£970**
717x595x1625 mm h

WITH ADJUSTABLE SHELF

- Central locking system to close upper and lower compartment - keyed alike
- Monitor leaf door with Plexiglass® window for visibility
- Retractable keyboard drawer with mouse holder
- Adjustable shelf
- Built-in ventilator and dust filter to protect equipment from overheating
- 4 Sockets with 1 m connecting cable
- Lower compartment closed with hinged doors: 661x467x700 mm h

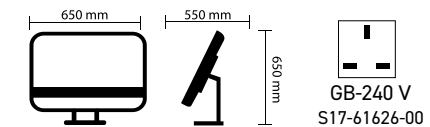

Part. No. SOCKET
S17-61626A-05/XX GB-240 V **£1040**
717x595x1753 mm h

MOBILE WITH ADJUSTABLE SHELF

- Central locking system to close upper and lower compartment - keyed alike
- Monitor leaf door with Plexiglass® window for visibility
- Retractable keyboard drawer with mouse holder
- Adjustable shelf
- Built-in ventilator and dust filter to protect equipment from overheating
- 4 Sockets with 1 m connecting cable
- Lower compartment closed with hinged doors: 661x467x700 mm h

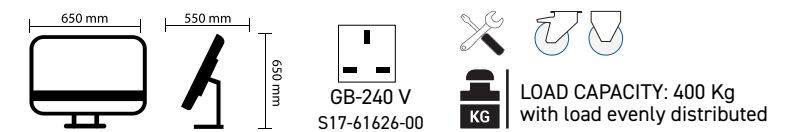

FLAT SCREEN COMPUTER CABINETS



STANDARD

Central locking system to close upper and lower compartment - keyed alike
 Monitor leaf door with Plexiglass® window for visibility
 Built-in ventilator and dust filter to protect equipment from overheating
 4 Sockets with 1 m connecting cable
 Lower compartment closed with hinged doors: 661x467x875 mm h

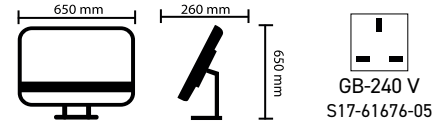

Part. No. SOCKET
 S17-61676-00/XX GB-240 V **£1152**
 717x595x1670 mm h



WITH ADJUSTABLE SHELF

Central locking system to close upper and lower compartment - keyed alike
 Monitor leaf door with Plexiglass® window for visibility
 Adjustable shelf
 Built-in ventilator and dust filter to protect equipment from overheating
 4 Sockets with 1 m connecting cable
 Lower compartment closed with hinged doors: 661x467x875 mm h

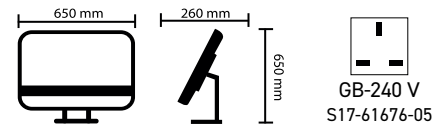

Part. No. SOCKET
 S17-61676-01/XX GB-240 V **£1194**
 717x595x1670 mm h



MOBILE WITH ADJUSTABLE SHELF

Central locking system to close upper and lower compartment - keyed alike
 Monitor leaf door with Plexiglass® window for visibility
 Adjustable shelf
 Built-in ventilator and dust filter to protect equipment from overheating
 4 Sockets with 1 m connecting cable
 Lower compartment closed with hinged doors: 661x467x875 mm h

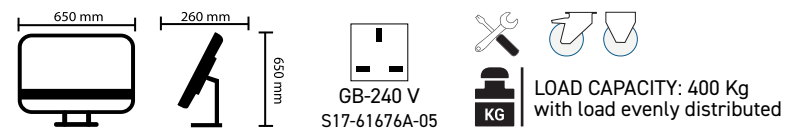

Part. No. SOCKET
 S17-61676A-05/XX GB-240 V **£1264**
 717x595x1798 mm h

NOTEBOOK CABINETS



STANDARD

1 Drawer 75 S
 Central locking system to close upper and lower compartment - keyed alike
 Built-in ventilator and dust filter to protect equipment from overheating
 4 Sockets with 1 m connecting cable
 Lower compartment closed with hinged doors: 661x467x750 mm h



Part. No. SOCKET
 S17-41006A-00/XX GB-240 V **£998**
 717x595x1128 mm h

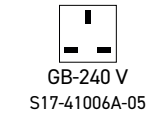

MOBILE WITH ADJUSTABLE SHELF

1 Drawer 75 S
 Central locking system to close upper and lower compartment - keyed alike
 Adjustable shelf
 Built-in ventilator and dust filter to protect equipment from overheating
 4 Sockets with 1 m connecting cable
 Lower compartment closed with hinged doors: 661x467x750 mm h



Part. No. SOCKET
 S17-41006A-05/XX GB-240 V **£1040**
 717x595x1128 mm h

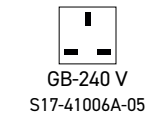

COLOUR

When ordering, please complete the article number by adding the desired two-digit colour code (e. g. S17-61626A-05/**04**)

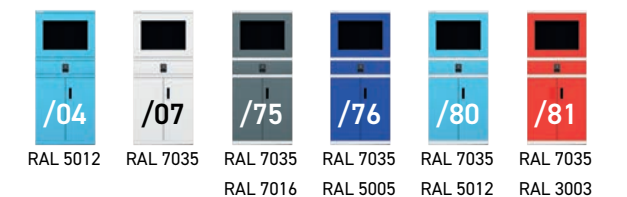

TOOL TROLLEY WITH 3 RACKS



	Part. No.	
without Tool holders	S30-10101-700/XX	£556
x40 ISO-SK 40	S30-10101-704/XX	£675
x25 ISO-SK 50	S30-10101-705/XX	£661
x40 HSK 63	S30-10101-708/XX	£780
x20 HSK 100	S30-10101-701/XX	£696
x30 CAPTO C6	S30-10101-709/XX	£773

1077x508x826 mm h

1 Fixed shelf with rubber mat

1 Fixed tool holder frame 3-rows Part. No. 30-45336

2 Tool cradles Part. No. 30-41360 and supports

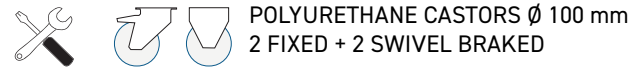

MACHINE CABINET WITH 2 DRAWERS + SHELF



	Part. No.	
without Tool holders	S15-31450-900/XX	£1040
x64 ISO-SK 40	S15-31450-904/XX	£1180
x40 ISO-SK 50	S15-31450-905/XX	£1124
x64 HSK 63	S15-31450-908/XX	£1348
x32 HSK 100	S15-31450-901/XX	£1194
x48 CAPTO C6	S15-31450-909/XX	£1348

717x748x1450 mm h

2 Drawers 100 T

2 Fixed tool holder frame 4-rows and supports

1 Retractable shelf T

TOOL TROLLEY WITH 5 RACKS



	Part. No.	
without Tool holders	S30-10100-800/XX	£661
x56 ISO-SK 40	S30-10100-804/XX	£794
x35 ISO-SK 50	S30-10100-805/XX	£759
x56 HSK 63	S30-10100-808/XX	£942
x28 HSK 100	S30-10100-801/XX	£808
x42 CAPTO C6	S30-10100-809/XX	£949

1077x508x880 mm h

1 Fixed shelf with rubber mat

1 Fixed tool holder frame 3-rows Part. No. 30-45336

4 Tool cradles Part. No. 30-41360 and supports

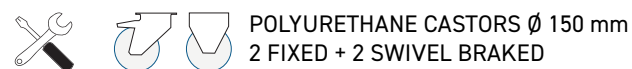

MACHINE CABINET WITH 3 DRAWERS



	Part. No.	
without Tool holders	S15-31000-800/XX	£1026
x64 ISO-SK 40	S15-31000-804/XX	£1138
x40 ISO-SK 50	S15-31000-805/XX	£1103
x64 HSK 63	S15-31000-808/XX	£1306
x32 HSK 100	S15-31000-801/XX	£1165
x48 CAPTO C6	S15-31000-809/XX	£1306

717x748x1020 mm h

3-sided upstand with rubber mat

1 Drawer 75 T

2 Drawers 100 T

2 Fixed tool holder frame 4-rows and supports

COLOUR

When ordering, please complete the article number by adding the desired two-digit colour code.



COLOUR

When ordering, please complete the article number by adding the desired two-digit colour code.

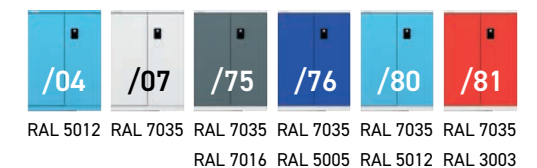

CNC STORAGE & TRANSPORT

TOOL HOLDER - 15 pcs. KIT



BUTTON

Tool type	Part. No.		∅	
ISO-SK 40	S30-51041	138x58x63 mm h	44,5 mm	£68
ISO-SK 50	S30-51051	138x105x63 mm h	69,9 mm	£75

Tool type	Part. No.		∅	
HSK 63	S30-51064	138x65x20 mm h	48,6 mm	£110
HSK 100	S30-51099	138x105x20 mm h	75 mm	£138

Tool type	Part. No.		∅	
CAPTO 6	S30-51616	138x82x30 mm h	47 mm	£131

CABINET WITH HINGED DOORS



	Part. No.	
without Tool holders	S24-32000-400/XX	£899
x156 ISO-SK 40	S24-32000-404/XX	£1306
x96 ISO-SK 50	S24-32000-405/XX	£1236
x144 HSK 63	S24-32000-408/XX	£1636
x84 HSK 100	S24-32000-401/XX	£1418
x108 CAPTO C6	S24-32000-409/XX	£1643
1026x555x2000 mm h		
4 Tool holder frame 3-rows Part. No. 30-43354 and supports		

CABINET WITH HINGED DOORS



	Part. No.	
without Tool holders	S24-32000-600/XX	£1026
x117 ISO-SK 40	S24-32000-604/XX	£1327
x72 ISO-SK 50	S24-32000-605/XX	£1278
x108 HSK 63	S24-32000-608/XX	£1559
x63 HSK 100	S24-32000-601/XX	£1404
x81 CAPTO C6	S24-32000-609/XX	£1531
1026x555x2000 mm h		
2 Adjustable shelves - Load capacity 70 kg		
3 Tool holder frame 3-rows Part. No. 30-43354 and supports		
2 Drawers 100 T		

COLOUR

When ordering, please complete the article number by adding the desired two-digit colour code.

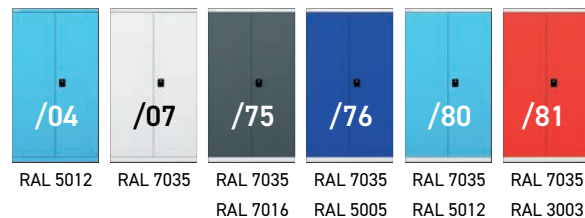

CNC TOOL STAND



	Part. No.	
without Tool holders	S30-23627-000/XX	£117
x24 ISO-SK 40	S30-23627-004/XX	£187
x15 ISO-SK 50	S30-23627-005/XX	£166
x24 HSK 63	S30-23627-008/XX	£257
x12 HSK 100	S30-23627-001/XX	£194
x18 CAPTO C6	S30-23627-009/XX	£250
588x500x255 mm h		

ROLLER SHUTTER CABINET



	Part. No.	
without Tool holders	S24-39200-400/XX	£1096
x156 ISO-SK 40	S24-39200-404/XX	£1517
x96 ISO-SK 50	S24-39200-405/XX	£1390
x144 HSK 63	S24-39200-408/XX	£1867
x84 HSK 100	S24-39200-401/XX	£1580
x108 CAPTO C6	S24-39200-409/XX	£1881
1040x600x2000 mm h		
4 Tool holder frame 3-rows Part. No. 30-43354 and supports		

ROLLER SHUTTER CABINET

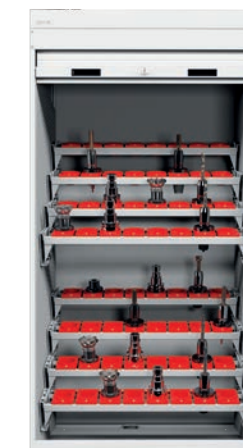

	Part. No.	
without Tool holders	S30-39200-200/XX	£1517
x112 ISO-SK 40	S30-39200-204/XX	£1909
x72 ISO-SK 50	S30-39200-205/XX	£1811
x112 HSK 63	S30-39200-208/XX	£2204
x64 HSK 100	S30-39200-201/XX	£1965
x88 CAPTO C6	S30-39200-209/XX	£2246
1040x635x2000 mm h		
8 Tool cradles Part. No. 30-41540 and supports		

COLOUR

When ordering, please complete the article number by adding the desired two-digit colour code.



STORAGE CUPBOARDS

HINGED DOORS



Part. No.
S24-32000-01/XX **£661**
1026x555x2000 mm h
4 Adjustable shelves - Load capacity 70 Kg

HINGED DOORS



Part. No.
S24-62000-01/XX **£731**
1026x555x2000 mm h - Plexiglass doors
4 Adjustable shelves - Load capacity 70 Kg

HINGED DOORS



Part. No.
S24-32000-13/XX **£857**
1026x555x2000 mm h
4 Adjustable shelves - Load capacity 70 Kg
3 Drawers 100 S - Load capacity 20 Kg

HINGED DOORS



Part. No.
S24-32020-17/XX without hooks **£829**
S124-32020-17/XX 20 HOOK KIT **£899**
1026x555x2000 mm h
2 Adjustable shelves - Load capacity 70 Kg
2 Drawers 100 S - Load capacity 20 Kg
2 Perforated back panels RAL7035

HINGED DOORS

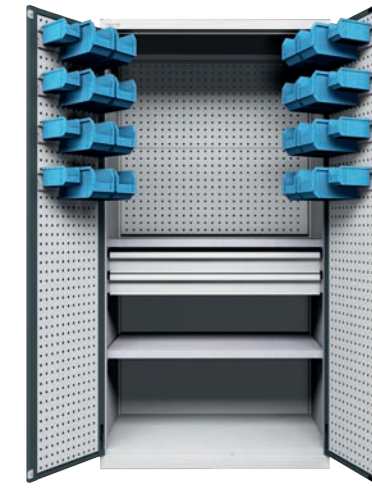

Part. No.
S24-32030-91/XX **£1040**
1026x555x2000 mm h
2 Adjustable shelves - Load capacity 70 Kg
2 Drawers 100 S - Load capacity 20 Kg
4 Perforated back panels RAL7035
8 Rails for containers
8 Containers size 1 - Blue
16 Containers size 2 - Blue

ROLLER SHUTTER



Part. No.
S124-39020-02/XX **£1068**
1040x600x2000 mm h
2 Perforated back panels RAL7035
2 Adjustable shelves - Load capacity 70 Kg
6 Compartments size 4 - Blue
20 HOOK KIT - S06-97020

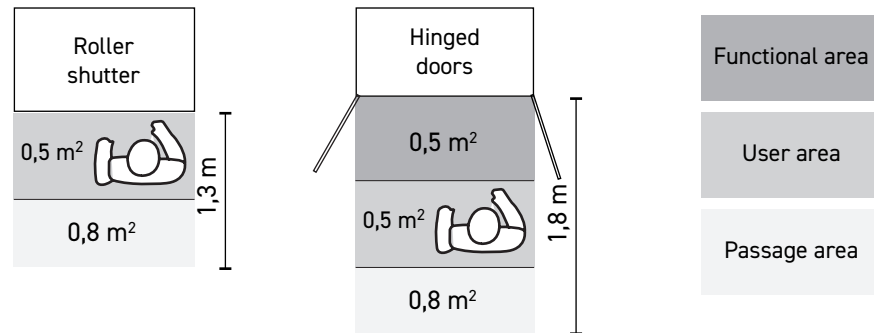

HOOKS

pg. 52

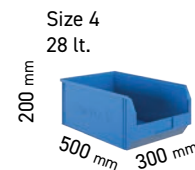
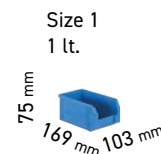

COLOUR

When ordering, please complete the article number by adding the desired two-digit colour code.

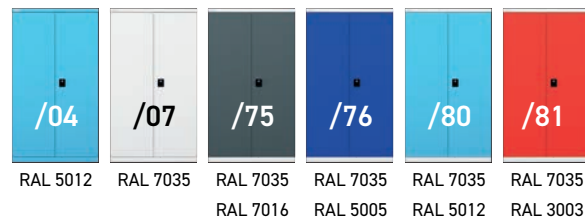

SLIDING DOORS



Part. No.
S26-42000-01/XX **£745**
1200x450x2000 mm h
4 Adjustable shelves - Load capacity 70 Kg

SLIDING DOORS



Part. No.
S27-42000-01/XX **£871**
1200x450x2000 mm h - Plexiglass doors
4 Adjustable shelves - Load capacity 70 Kg

COLOUR

When ordering, please complete the article number by adding the desired two-digit colour code.



TROLLEYS SERIES 77

TROLLEY



Part. No.
S177-30100-08 **£660**
745/825x620x1408 mm h
4 Shelves
8 Containers 400x300x120 mm h

TROLLEY



Part. No.
S177-30100-14 **£647**
745/825x620x1408 mm h
2 Perforated back panels
2 Shelves
4 Containers 400x300x120 mm h
15 HOOK KIT - S06-97015

TROLLEY



Part. No.
S177-31100-24 **£1068**
1043/1123x620x1408 mm h
14 Shelves
84 Containers size 2
without labels

TROLLEY



Part. No.
S177-31100-44 **£752**
1043/1123x620x1408 mm h
6 Shelves
18 Containers size 2
12 Containers size 3
without labels

TROLLEY



Part. No.
S177-31100-12 **£745**
1043/1123x620x1408 mm h
4 Shelves
12 Containers 400x300x120 mm h

TROLLEY



Part. No.
S177-31100-16 **£738**
1043/1123x620x1408 mm h
2 Perforated back panels RAL7035
2 Shelves
6 Containers 400x300x120 mm h
15 HOOK KIT - S06-97015

HOOKS

pg. 52



TROLLEY



Part No.
S177-31100-74 **£815**
1043/1123x620x1408 mm h
6 Shelves
28 Containers size 3B
without labels

TROLLEY



Part. No.
S177-31100-54 **£802**
1043/1123x620x1408 mm h
5 Shelves
20 Containers size 3
without labels

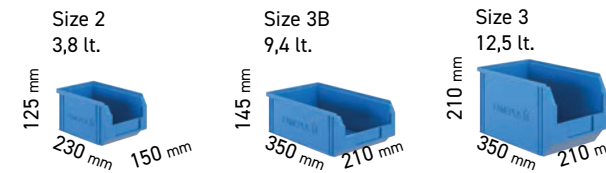

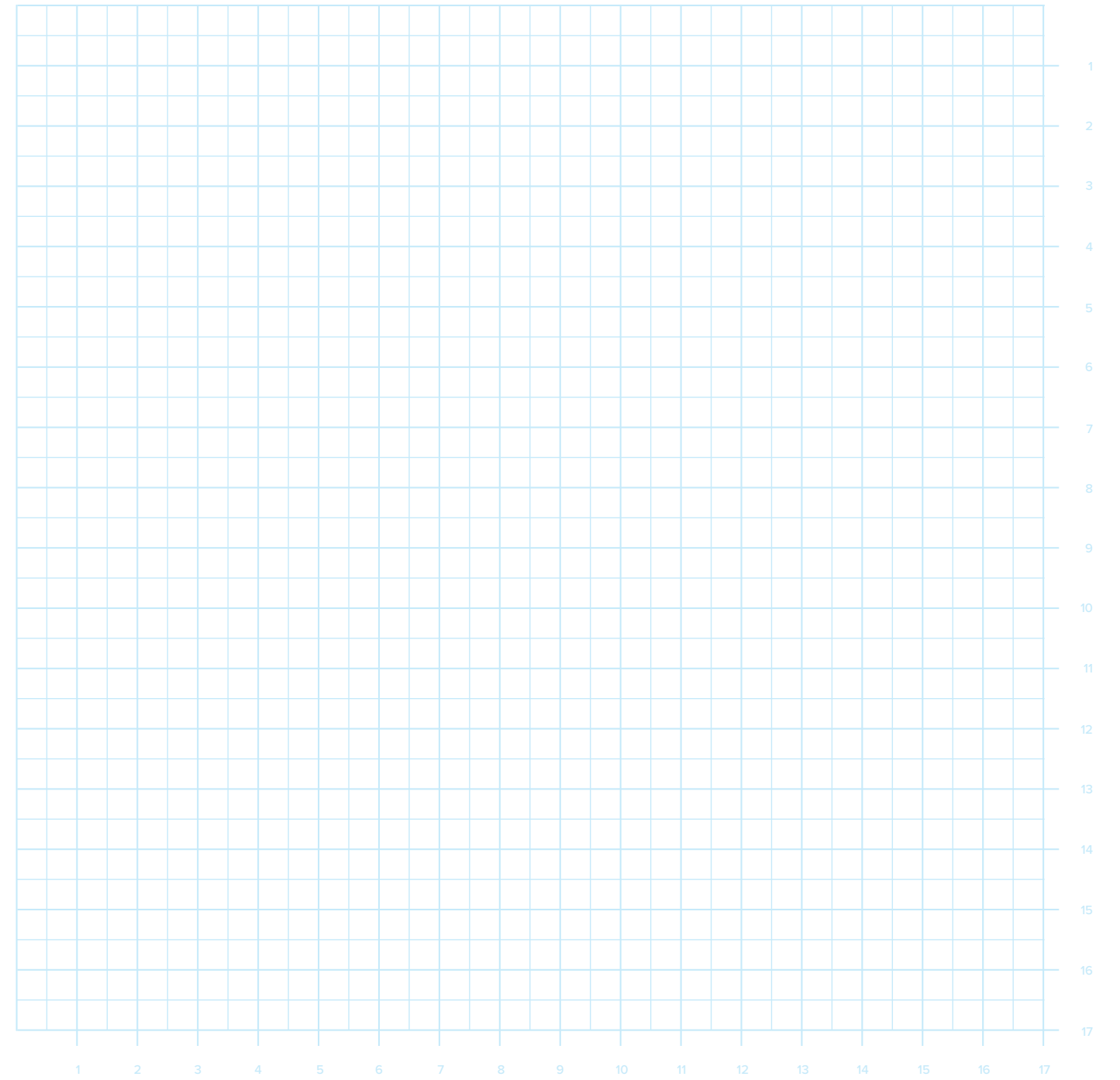
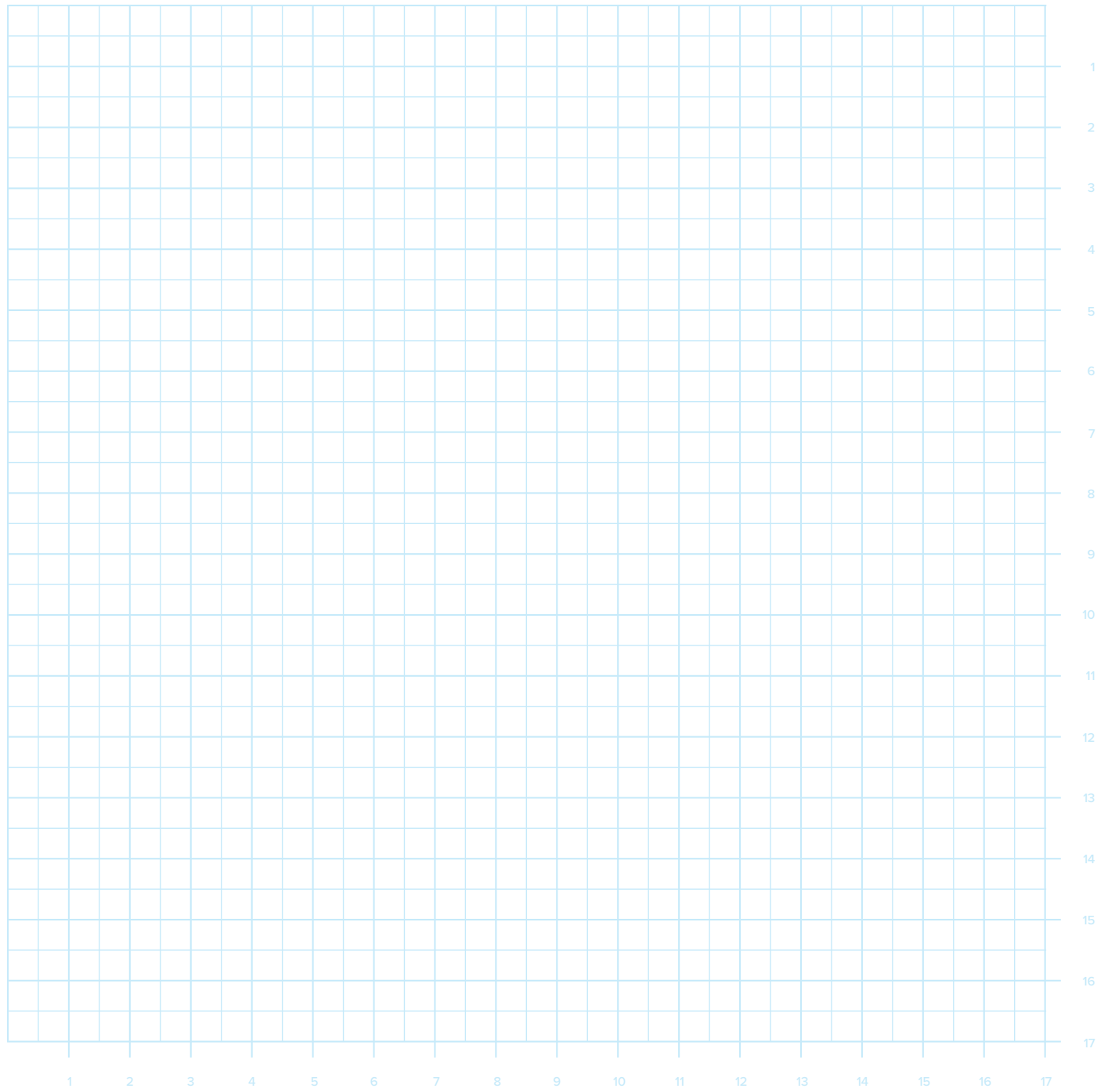

SPANNER CONVERSION SIZES

Millimeters	Inches	Fractional	Millimeters	Inches	Fractional
1	0.39	1/16"	13	0.748	3/4"
3	0.118	1/8"	14	0.827	13/16"
4	0.197	3/16"	15	0.866	7/8"
5	0.236	1/4"	16	0.954	15/16"
6	0.315	5/16"	17	0.984	1"
7	0.394	3/8"	18	1.102	1 1/8"
8	0.433	7/16"	19	1.181	1 1/4"
9	0.512	1/2"	20	1.378	1 3/8"
10	0.551	9/16"	21	1.575	1 1/2"
11	0.630	5/8"	22	1.772	1 3/4"
12	0.669	11/16"	23	1.969	2"

1 Foot = 0.30 Metres
 1 Metre = 3.28 Feet

Terms and conditions:

All prices in this catalogue include UK Mainland carriage (kerbside only) and exclude VAT. We reserve the right to charge extra for delivery to the following postcode areas: IV, KW, PH, AB, DD, KY, FK, PA and HS. Freight to Northern Ireland, Channel Islands, Isle of Wight and Isle of Man will not be paid by the Seller. We reserve the right to modify without prior notification any details stated in this catalogue regarding product features, versions and designs. No liability for printing errors or mistakes shall be assumed.

POLSTORE

0800 008 6861

www.polstore.co.uk

enquiries@polstore.co.uk

[!\[\]\(e3f8612927870f2e0f9f5989e6dd3064_img.jpg\) !\[\]\(a86c7d1c9cb81c81614634a31267440d_img.jpg\) !\[\]\(ce158fc5e55633398941d0898ae45661_img.jpg\) /polstoreuk](#)

Polstore Storage Systems Ltd
Unit 10, The Pines Trade Centre
Broad Street, Guildford
Surrey GU3 3BH